



Probe Selection Guide

More than 50 different probe models for wafer, package and board level characterization.



FormFactor offers a wide selection of engineering probes to meet the highly demanding and broad range of on-wafer and signal integrity applications.

Our families of RF, mixed-signal and DC probes are designed to meet the many challenges of the various probing environments and provide a durable, high-performance product that exceeds expectations.

Table of Contents

Probe Family Overview	3
Quick Probe Selection Guides	
Probe Selection Guide: RF Probes	5
Probe Selection Guide: Waveguide Probes	6
Probe Selection Guide: Mixed-Signal Probes	7
Probe Selection Guide: DC Multi-Contact Probes	8
Electrical Considerations When Specifying Probes	9
Single and Dual RF/Microwave Probes (Coaxial and Waveguide)	
Broadband Coaxial Probes	
NEW InfinityXT™ Probes	10
Infinity Probes® – Coaxial	12
Air Coplanar Probes® (ACP) – Coaxial	15
T-Wave™ Broadband Probes	18
IZI Probes® – Coaxial	20
Waveguide Probes	
Infinity Probes – Waveguide	14
Air Coplanar Probes® (ACP) – Waveguide	17
T-Wave™ Broadband Probes	18
T-Wave™ Banded Probes	19
RFIC and Functional Test (Multi-contact) Probes	
RF/Logic/Power	
InfinityQuad™ Probes	23
Unity Probes™	24
ACP Quadrant Probes	25
Multi-IZI Probes	26
Logic and Power	
Eye-Pass® Probes	27
DCQ and WPH Probes	28
Board Test and Signal Integrity Probes	
Fixed-pitch Compliant Probes (FPC)	29
IZI Probe® PCB	30
Special-purpose RF/Microwave Probes	
Cryogenic Probes	31
Light Wave Probes	32
Termination and Resistive Matching Probes	33
Calibration, System Solutions and Accessories	
WinCal XE™ RF Calibration Software	34
VNA Calibration Substrates (ISS, CSR, and Other)	35
Compatible System Solutions	37
Accessory Waveguide Extensions	40
Cables, Cleaning Accessories	42
Drawing Appendix	43

➤ Probe Family Overview

FormFactor offers a wide selection of engineering probes to meet the highly demanding and broad range of on-wafer and signal integrity applications. Our families of RF, mixed-signal and DC probes are designed to meet the many challenges of the various probing environments and provide a durable, high-performance product that exceeds expectations.



***NEW* InfinityXT™**

InfinityXT™ enhances and extends FormFactor's industry-leading Infinity probe family, which has set the benchmark for accuracy and repeatability in the device characterization and modeling community for more than a decade. The new InfinityXT series advances the industry standard with higher temperature range, better tip visibility and durability, and support for narrower pitches as the market evolves. [\(page 10\)](#)

Infinity Probes



The Infinity Probe series is an ideal match for device characterization and modeling and differential applications, with industry-leading performance. With its unique microstrip architecture and proprietary thin-film and coaxial probe technology, that reduces unwanted couplings to nearby devices and transmission modes. The Infinity Probe provides unmatched performance in both single-signal and dual-signal (differential) applications, providing extremely low contact resistance on aluminum pads with unsurpassed RF measurement accuracy for highly reliable, repeatable measurements. The Infinity Probe is designed for on-wafer/planar surface work only [\(page 12\)](#)

Air Coplanar Probes



The Air Coplanar Probe (ACP) is a rugged microwave probe with a compliant contact for accurate, repeatable measurements for both on-wafer as well signal integrity applications. It features excellent probe-tip visibility and the lowest loss available. Configurations for both single and dual signal applications are available. The ACP probe combines outstanding electrical performance with precise probe mechanics and is today's most widely used microwave probe available. [\(page 15\)](#)

T-Wave™ Probes



The T-Wave™ Probes enable wafer-level electrical measurement of millimeter wave devices and materials up to 1.1 THz, setting the industry performance standard for characterization of millimeter and sub-millimeter wavelength devices. The T-Wave Probes deliver low insertion loss and low contact resistance when probing gold pads. [\(page 19\)](#)

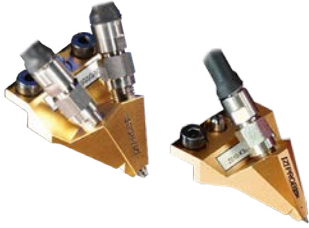

IZI Probes

The IZI Probes with coverage up to 67 GHz assure long probe lifetime and accurate measurements with superior tip compliance. The RF/Microwave signal makes only one transition to the coplanar contact structure within the shielded, air-isolated probe body maintaining signal integrity over a temperature range from 10 K to 300°C. ([page 21](#))

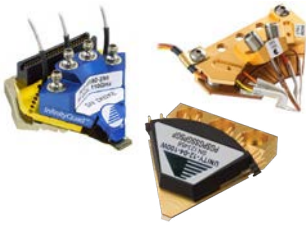

RFIC and Functional Test (Multi-contact) Probes

FormFactor offers a variety of durable, high-performance mixed-signal multi-contact probes to streamline RFIC engineering test and production applications, with some with high frequency capabilities up to 110 GHz. The multi-contact probe families include **InfinityQuad probe, Multi-IZI Probe, Unity Probe, ACP RF quadrant probe, Eye-Pass probe, DCQ and WPH probes.** ([page 23](#))

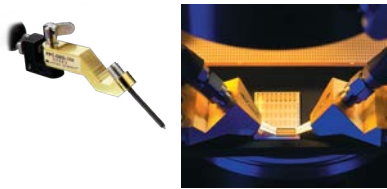

Board Test and Signal Integrity Probes

FormFactor offers a variety of precision, durable probes, ideal for signal integrity probing on IC packages and circuit board work. These probes offer high tip to tip compliance for uneven surfaces and deep reach capabilities to access contacts over adjacent components. Probes are available to meet the performance requirements of both circuit work or material characterization ([page 29](#))



Special-purpose RF/Microwave Probes

FormFactor offers many types of custom probes, so if an exact match is not found in this guide, please contact us for a review to determine if we have a probe that will fit your requirements or if we can customize a probe to fit your application. Some example applications/probes are ([page 31](#)):

- Cryogenic Probes
- Resistive matching / Termination probes
- Optical probes

The estimated lifetime indicated in this document can be negatively affected by several variables, such as overtravel used, planarity of the substrate, materials being probed, debris on the surface, skating into passivation, temperature, cleaning frequency and cleaning media.

➤ Quick Probe Selection Guide: RF Probes

Key Specifications		Z Probes		Infinity		InfinityXT	ACP	
		Single	Dual	Single	Dual	Single	Single	Dual
Maximum Frequency		67 GHz	50 GHz	145 GHz	145 GHz ⁷	110 GHz	110 GHz	110 GHz
Minimum Pad Size		50x50 μm	50x50 μm	25x35 μm	25x35 μm	25x35 μm	80x80 μm	80x80 μm
Typical Insertion Loss @ 40 GHz		0.8 dB	0.8 dB	0.7 dB	0.9 dB	0.8 dB	1.0/0.6 dB ³	1.25 dB
Compliance		50/300 μm ¹	50 μm	1 μm	1 μm	1 μm	25 μm	25 μm
Standard Pitch Range		50-1250 μm	100-500 μm	50-250 μm	100-250 μm	50-250 μm	100-1250 μm	100-500 μm
Maximum DC Current		1.5 A	1.5 A	0.5/2 A ⁴	0.5 A	0.5 A	5 A	5 A
Typical Maximum Voltage		100 V	100 V	200 V	200 V	200 V	200 V	200 V
Maximum RF Power @ 2 GHz		15/65 W ²	15 W	37 dBm	37 dBm	37 dBm	30 W	30 W
Typical Lifetime on Al Pads		>1,000,000	>1,000,000	>250,000	>250,000	>250,000	>500,000	>500,000
Maximum Temperature		300°C	300°C	125°C	125°C	175°C ⁵	200°C	200°C
Cryogenic Capable		Yes	Yes	No	No	No	Yes	Yes
Typical Contact Resistance on Al		50 mΩ	50 mΩ	30 mΩ	30 mΩ	30 mΩ	100 mΩ	100 mΩ
Device Modeling and Characterization - Si	2-Port S-Parameter Measurements	DC-67 GHz	●		●		●	○
		67-110 GHz			●		●	○
	Differential S-Parameter Measurements	DC-67 GHz		●		●		○
		67-110 GHz				●		○
	Load-Pull Measurements	DC-67 GHz	●		●		●	○
		67-110 GHz			●		●	○
Device Modeling and Characterization - GaAs	2-Port S-Parameter Measurements	DC-67 GHz	●		●		●	
		67-110 GHz			●		●	
	Differential S-Parameter Measurements	DC-67 GHz		●		●		●
		67-110 GHz				●		●
	Load-Pull Measurements	DC-67 GHz	●		●		●	●
		67-110 GHz			●		●	●
Production Testing - RF Discrete Devices	Al Pads	DC-67 GHz	●	For multi-port	●	●	●	
		67-110 GHz			●	For multi-port	●	
	Au Pads	DC-67 GHz	●	For multi-port	○	○	○	●
		67-110 GHz			○	○	○	●
PCB Board Tests ⁶	Single Signal	DC-67 GHz	●				●	
		67-110 GHz					●	
	Multi-port/Differential	DC-67 GHz		●				●
		67-110 GHz						●

● = Best (Recommended) ● = Good ○ = Acceptable NR = Not Recommended

¹ For |Z| Probe PCB
² For high-power |Z| Probe
³ For low-loss ACP probe
⁴ For high-current Infinity Probe
⁵ Spec to 175°C, type tested to 200°C
⁶ Infinity probes available up to 500 GHz
⁷ Available upon request

> Quick Probe Selection Guide: WaveGuide Probe Guide

		Key Specifications	T-Wave	Infinity	ACP
		Maximum Frequency	1.1 THz	500 GHz	140 GHz
		Minimum Pad Size	25x35 μm	25x35 μm	80x80 μm ¹
		Compliance	1 μm	1 μm	25 μm
		Standard Pitch Range	25-100 μm	50-150 μm	100-250 μm
		Typical Lifetime on Al Pads	NS	>250,000	>500,000
		Maximum Temperature	125°C	125°C	200°C
		Typical Contact Resistance on Al	300 m Ω	30 m Ω	100 m Ω
Device Modelling and Characterization	Al Pads				
	Au Pads				
Product Testing - RF Discrete Devices	Al Pads				
	Au Pads				
PCB Board Test	Single Signal		NR	NR	
Available Waveguide Bands	WR - 15 (50 GHz - 75 GHz)			✓	✓
	WR - 12 (60 GHz - 90 GHz)			✓	✓
	WR - 10 (75 GHz - 110 GHz)			✓	✓
	WR - 8 (90 GHz - 140 GHz)			✓	✓
	WR - 6 (110 GHz - 170 GHz)			✓	
	WR - 5 (140 GHz - 220 GHz)		✓	✓	
	WR - 3 (220 GHz - 325 GHz)		✓	✓	
	WR - 2 (325 GHz - 500 GHz)		✓	✓	
	WR - 1.5 (500 GHz - 750 GHz)		✓		
	WR - 1 (750 GHz - 1.1 THz)		✓		

= Best (Recommended)
 = Good
 = Acceptable
 NR = Not Recommended

¹Smaller pad sizes addressed with Reduced Contact (RC) tips (typically 50 x 60 μm pads)

➤ Quick Probe Selection Guide: Mixed-signal / Multi-contact Probes

			Key Specifications					
			InfinityQuad	Multi IZI	Unity	ACP-Q		
Maximum Number Contacts			25	35	12	16		
Maximum Frequency			110 GHz	20 GHz	20 GHz	110 GHz		
Maximum Number RF Signals			25	16	8	3		
Recommended Minimum Pad Size			30x50 μm	60x60 μm	95x95 μm	80x80 μm		
Power De-coupling			EyePass	On-board	EyePass	On-Tip		
Non-Uniform Pitch			Yes	Yes	No	Yes		
Maximum Temperature			125°C	200°C	125°C	125°C		
Cryogenic Capable			No	Yes	No	No		
Online Design Capture			Yes	Excel Form	Yes	PDF Form		
IC Test Engineering	Characterization and Verification	Uniform Pitch	<20 GHz	●	●	●	○	
			>20 GHz	●	NR	NR	○	
		Non-Uniform Pitch	<20 GHz	●	●	NR	●	
			>20 GHz	●	NR	NR	●	
	Failure Analysis and Design Debug	Uniform Pitch	<20 GHz	●	●	●	○	
			>20 GHz	●	NR	NR	○	
		Non-Uniform Pitch	<20 GHz	●	●	NR	●	
			>20 GHz	●	NR	NR	●	
Production Test	Pre-Production	Uniform Pitch	<20 GHz	●	●	●	○	
			>20 GHz	●	NR	NR	○	
		Non-Uniform Pitch	<20 GHz	●	●	NR	●	
			>20 GHz	●	NR	NR	●	
	Small Scale Production	Uniform Pitch	<20 GHz	●	●	●	○	
			>20 GHz	●	NR	NR	○	
		Non-Uniform Pitch	<20 GHz	NR	●	NR	●	
			>20 GHz	NR	NR	NR	●	
	Large Scale Production	Uniform Pitch	<20 GHz	●	●	●	○	
			>20 GHz	●	NR	NR	○	
		Non-Uniform Pitch	<20 GHz	NR	●	NR	●	
			>20 GHz	NR	NR	NR	●	
	Application Specific	Small Pads and Scribe-Street Devices	Uniform Pitch	<20 GHz	●	○	NR	NR
				>20 GHz	●	NR	NR	NR
			Non-Uniform Pitch	<20 GHz	NR	○	NR	NR
				>20 GHz	NR	NR	NR	NR
mm-Wave Complex IC test (Wireless HDMI, Automobile Radar)		Uniform Pitch	—	●	NR	NR	●	
		Non-Uniform Pitch	—	NR	NR	NR	Recommend uniform pitch pads	
PCB Board Test		Uniform Pitch	<20 GHz	NR	●	○	●	
			>20 GHz	NR	NR	NR	●	
		Non-Uniform Pitch	<20 GHz	NR	●	NR	●	
			>20 GHz	NR	NR	NR	●	
Package Device Probing		Uniform Pitch	<20 GHz	●	●	○	●	
			>20 GHz	●	NR	NR	●	
		Non-Uniform Pitch	<20 GHz	●	●	NR	●	
			>20 GHz	●	NR	NR	●	

● = Best (Recommended) ● = Good ○ = Acceptable NR = Not Recommended

Quick Probe Selection Guide: DC Multi-contact Probes

Key Specifications			Eye-Pass	DCQ	WPH-900	Multi IZI	Infinity Quad (DC only ver.)
Maximum Number Contacts			12	24	12	35	25
Power De-coupling			At tip and on-PCB	On tip blade	On-PCB	At tip and on-PCB	At tip and on-PCB
Maximum Current			1 A	500 mA	500 mA	1 A	400 mA
Maximum Voltage			50 V	50 V ¹	50 V	100 V	50 V
RF Bandwidth			500 MHz	500 MHz	500 MHz	500 MHz	500 MHz
Typical Lifetime on AI Pads			>250,000	>250,000	>250,000	>1,000,000	>250,000
Recommended Minimum Pad Size			95x95 µm	50x50 µm	50x50 µm	60x60 µm	25x35 µm
Non-Uniform Pitch			No	Yes	Yes	Yes	Yes
Maximum Temperature			125°C	125°C	125°C	200°C	125°C
Cryogenic Capable			No	No	No	Yes	No
Online Design Capture			Yes	PDF Form	PDF Form	Excel Form	Yes
Contact Compliance			Yes	Yes	Yes	Yes	No ²

IC Test Engineering	Simple IC Bias and Control	Uniform Pitch	<16 contacts	●	●	●	●	●
			>16 contacts	NR	NR	NR	●	●
Characterization and Verification	Uniform Pitch	<16 contacts	●	●	●	●	●	
		>16 contacts	NR	NR	NR	●	●	
	Non-Uniform Pitch	<16 contacts	NR	●	●	●	●	
		>16 contacts	NR	NR	NR	●	●	
Failure Analysis and Design Debug	Uniform Pitch	<16 contacts	●	●	●	●	● ²	
		>16 contacts	NR	NR	NR	●	● ²	
	Non-Uniform Pitch	<16 contacts	NR	●	●	●	● ²	
		>16 contacts	NR	NR	NR	●	● ²	
Production Test	Pre-Production	Uniform Pitch	<16 contacts	●	●	●	●	●
			>16 contacts	NR	NR	NR	●	●
		Non-Uniform Pitch	<16 contacts	NR	●	●	●	●
			>16 contacts	NR	NR	NR	●	●
	Small Scale Production	Uniform Pitch	<16 contacts	●	●	●	●	●
			>16 contacts	NR	NR	NR	●	●
		Non-Uniform Pitch	<16 contacts	NR	●	●	●	●
			>16 contacts	NR	NR	NR	●	●
Large Scale Production	Uniform Pitch	<16 contacts	●	●	●	●	●	
		>16 contacts	NR	NR	NR	●	●	
	Non-Uniform Pitch	<16 contacts	NR	●	●	●	●	
		>16 contacts	NR	NR	NR	●	●	

● = Best (Recommended) ● = Good ○ = Acceptable NR = Not Recommended

¹ Maximum voltage is 50 V without power bypassing, 25 V with standard power bypassing, and component dependent with custom power bypassing option.

² For wafer or substrate pads only.

➤ Electrical Considerations When Specifying Probes

Primary Frequency Range and Performance Limitations

With RF / Microwave and millimeter-wave probes, the specified and usable performance range is based on a combination of multiple probe attributes. The most basic or fundamental of which is the coaxial connector limitation. However, it is important to note that a probes bandwidth or upper frequency limitation can also be impacted (limited) by other probe attributes. Below are some of the most significant attributes that can impact both spec'd and useable bandwidth / upper frequency limitations:

Tip Configuration

- For single line probes
 - Balanced GSG contacts offer the best performance
 - Whereas GS/SG configurations can reduce useable frequency range
- For dual line probes (cross talk between the signal lines is a frequency limiting parameter)
 - Balanced GSGSG contacts offer the best performance
 - While GSSG configurations will further reduce useable frequency range in most cases

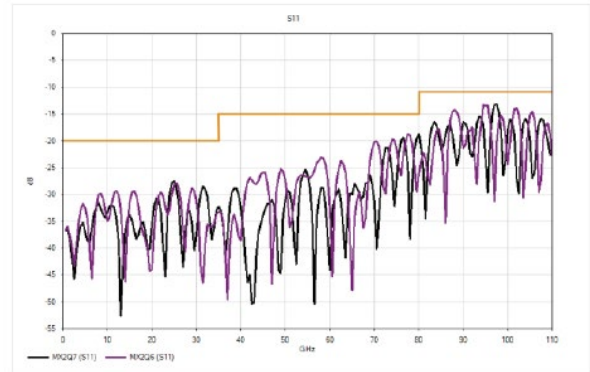

Typical Return Loss thru 110 GHz for a GSG 50 µm probe (specifications can vary slightly by pitch). — spec limit

Tip Pitch, Wide Pitches (e.g. >250 µm can also reduce useable frequency range)

- Wide pitches increase the ground path inductance
 - E.g. for frequency ranges up to 40 GHz pitches, < 250 µm is recommended. As you go higher in frequency, smaller pitches may be required.
- Further as the contact pitch increases, to the point that the pitch becomes a significant percentage of the wavelength of the desired measurement frequencies, this also becomes a frequency limiting parameter, as moding and other issues are likely to occur

Application/Accuracy Expectations

- S-Parameter measurements is one of the most demanding applications and because of this, this is the basis for most of our frequency specifications
- TDR measurement can typically be done at up to 2x that of S-Parameter measurements range
- General signal integrity measurements can also typically be done up to 1.5-2x that of S-Parameter measurements

Product Architecture (e.g. Microstrip vs CPW)

- Microstrip probe tip architecture helps to limit or contain field radiation and coupling from the probe tip structure to other adjacent signals (such as in dual probes, helping to limit cross talk) and unwanted probe to DUT coupling. FormFactor's Infinity products are the only probes on the market that offer this technology in their tip structures

Probe RF Connector Types

Connector Type	Best Case Frequency Limit
2.92 mm/K connector	40 GHz
2.4 mm	50 GHz
1.85 mm	67 GHz
1 mm	110 GHz (extended 130 GHz)
0.8 mm	145 GHz

Note: 2.92 mm connectors are mate-able with SMA & 3.5 mm connectors (but at reduced bandwidth)

FormFactor recommends that during DUT layout, consideration be given to testability and to take the attributes discussed here into consideration to attain optimum performance. Our field sales and application engineers are available and happy to consult with you on these topics as needed.

> InfinityXT™ Probe



InfinityXT™ Probe RF/mmW Probe Series IXT40, IXT50, IXT67, and IXT110

The development of the new InfinityXT™ probe has been guided by the requirements of explosive growth in the RF and microwave devices, driven by the automotive, mobile communications/5G and IoT devices. The requirements include ultra-wide bandwidth and wide temperature ranges for device modeling and characterization. The InfinityXT series delivers on these and more, with higher temperature range, better tip visibility and durability, and support for narrower pitches as the market technologies evolve.

InfinityXT probes are compatible with FormFactor's Autonomous RF Measurement Assistant, which enables fully autonomous, hands-free RF and mmW calibrations and measurements over multiple temperatures ([page 37](#)).

Features

- Superior high frequency and electrical performance
- High temperature capability (175°C +) for automotive device characterization and other applications
- Better tip visibility for enhanced placement accuracy and repeatability
- Improved tip life/durability with solid rhodium contacts
- New tip architecture enables support for narrower pitches (e.g. 25 µm)
- Advanced mechanical design combined with small contacts enables probing on smaller pads/pitches and improves durability and robustness

Advantages

- Excellent return and insertion loss combined with low and repeatable contact resistance on aluminum pads. This helps to ensure high-accuracy S-parameter measurements to meet the requirements of the most demanding applications.
- Superior field confinement reduces unwanted couplings to nearby devices and transmission modes.
- Performance from -50°C to +175°C, without compromising accuracy or life (demonstrated useable to 200°C)
- Industry-leading solution for small pad, tight pitch, RF probing needs. Small, lithographically-defined contacts with a contact area of 12 µm W x 5 µm L.
- Longer probe life due to highly durable, solid rhodium contacts and new mechanical architecture.

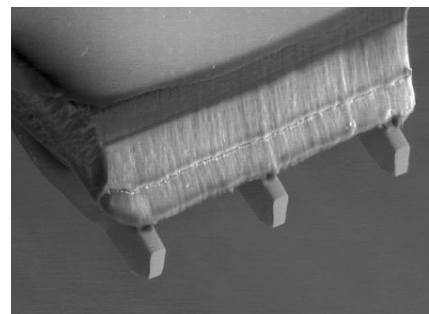

SEM image of InfinityXT 100 µm pitch contacts highlights the highly visible, small 12 µm wide contacts.

> InfinityXT™ Probe

Mechanical Specifications

Available contact configurations	IXT40 - GS /SG/GSG, IXT50 - GS /SG/GSG, IXT67 - GS /SG/GSG, IXT110 GSG Only Recommended
Available contact pitches	45, 50, 55, 60, 65, 70, 75, 80, 90, 100, 125, 150, 175, 200, 225, and 250 μm (pitches between 25 – 40 μm , contact field sales or applications to discuss your requirements)
Contact material	Non-oxidizing solid rhodium tips
Minimum recommended pad size	20 μm x 40 μm (but can be used on small pads in Y, with careful probe placement)
Contact area	W12 μm x L5 μm (nominally, at initial use, length will extend some with use)
Operating temperature	-40°C to +175°C (maximum temperature range: -55°C to +200°C)
Recommended overtravel	30-75 μm
Maximum safe overtravel	150 μm
Overtravel to skate ratio	2.5:1 (50 μm overtravel : 20 μm skate)
Body Styles	IXT40, IXT50 Angled only, IXT67, IXT110 Angled and vertical

S-Parameter Specifications

IXT40 (GSG)	0-20 GHz	20-40 GHz	
Return Loss (S11)	20 dB	15 dB	
Insertion loss (S12)	0.8 dB	1 dB	
IXT40 (GS/SG)	0-20 GHz	20-40 GHz	
Return Loss (S11)	20 dB	13 dB	
Insertion loss (S12)	0.8 dB	1.2 dB	
IXT50 (GSG)	0-20 GHz	20-50 GHz	
Return Loss (S11)	20 dB	13 dB	
Insertion loss (S12)	1 dB	1.5 dB	
IXT50 (GS/SG)	0-20 GHz	20-50 GHz	
Return Loss (S11)	20 dB	13 dB	
Insertion loss (S12)	1 dB	1.5 dB	
IXT67 (GSG)	0-25 GHz	25-40 GHz	40-67 GHz
Return Loss (S11)	20 dB	15 dB	12dB
Insertion loss (S12)	0.8 dB	1 dB	1.5 dB
IXT67 (GS/SG)	0-25 GHz	25-40 GHz	0-67 GHz
Return Loss (S11)	20 dB	13 dB	11 dB
Insertion loss (S12)	0.8 dB	1.2 dB	1.8 dB
IXT110 (GSG)	0-35 GHz	35-80 GHz	80-110 GHz
Return Loss (S11)	20 dB	15 dB	11 dB
Insertion loss (S12)	1 dB	1.5 dB	2 dB

Note: Probe S-Parameter files “s2p” are available at the following [link](#). You will need the exact PN and SN of the probe to download the s2p file.



InfinityXT GSG-50 scrub marks at progressively higher overtravel levels of 13, 25, 50 and 75 μm .
Highly uniform scrub yields very high repeatability in your measurements.

> Infinity Probes



Infinity Probe sets the benchmark for the device characterization and modeling community

The Infinity probe is truly unique in its architecture that delivers industry leading performance. This revolutionary probe combines extremely low contact resistance on aluminum pads with unsurpassed RF measurement accuracy to provide highly reliable, repeatable measurements. The Infinity Probe reaches this new performance level through the combination of FormFactor's proprietary thin-film technology and coaxial probe technology.

Infinity probes are compatible with FormFactor's Autonomous RF Measurement Assistant, which enables fully autonomous, hands-free RF and mmW calibrations and measurements over multiple temperatures [\(page 37\)](#).

Features

- Lithographic thin-film construction
- Non-oxidizing nickel alloy tips
- Innovative force delivery mechanism
- 40 to 500 GHz versions
- GSG, SG/GS, GSGSG, GSSG, SGS configurations
- Probe pitch as narrow as 50 μm
- High-current version (2 A) available
- Typical lifetime > 250,000 touchdowns on Al pads

Advantages

- Superior field confinement reduces unwanted couplings to nearby devices and transmission modes
- Low, stable contact resistance
- Superior measurement accuracy and repeatability
- Small scrub minimizes damage to aluminum pad
- Typical contact resistance: < 0.05 Ω on Al, < 0.02 Ω on Au
- Save valuable wafer space and reduce pad parasitics by being able to shrink pad geometries to 25 x 35 μm (best case)
- Reduction in modeling and design cycle time

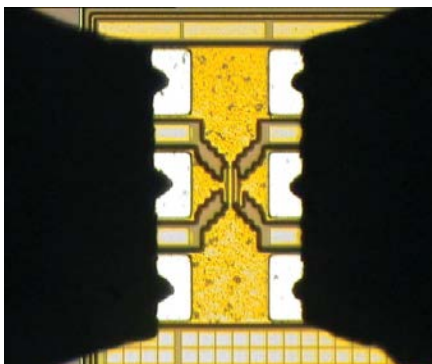

Infinity Probe contacting silicon RF device

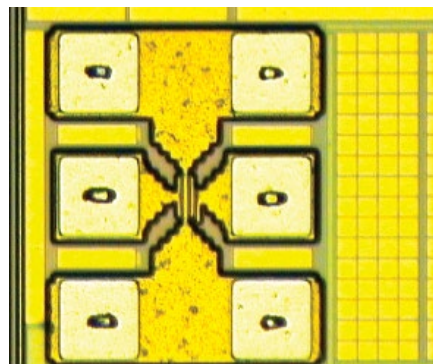

Small contact marks enable contact to small pads



Autonomous RF Measurement Assistant with Infinity probes

> Infinity Probes

Part Number Key

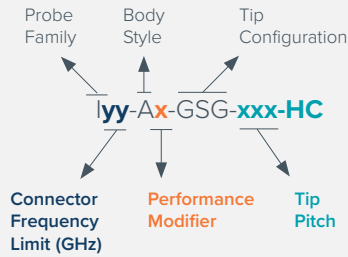

Characteristic	Available values
Coaxial Conn. (Frequency)	40 GHz = 2.92 mm, 50 GHz= 2.4 mm, 65 GHz = 1.85 mm, 110 GHz = 1 mm
Body Style - Coaxial and Wave Guide	Blank = Vertical, A = Angled, D = Dual Vertical (Dual angled not avail.), S = Short Wave Guide, T = Tall Wave Guide
Performance Modifier	Blank = Standard, M = Modeling Version
Tip Configuration	GS, SG, GSG, GSSG, GSGSG (SSG, GSS) ¹
Tip Pitches	50-250 in 25 μ m increments, larger values may be available (check with factory)
Suffix (Tip modifier)	Blank = Standard microstrip version, HC = High-current version (CPW tip structure)

Note: Not all combinations are available.

Contact configuration	GSG, SG, GS	Connector	GSGSG, GSSG, SGS
Frequency range for coaxial probes	I40 – DC to 40 GHz	I40 - 2.92 mm (f)	I40
	I50 – DC to 50 GHz	I50 - 2.4 mm (f)	I50
	I67 – DC to 67 GHz	I67 - 1.85 mm (f)	I67
	I110 – DC to 110 GHz (GSG)	I110 - 1 mm (f)	I110
	I145 - DC to 145 GHz (GSG)	I145 - 0.8 mm (f)	NA
Typical insertion loss (GSG, GSGSG versions only)			
DC to 40 GHz	0.7 dB		0.9 dB
40 to 50 GHz	0.8 dB		0.9 dB
50 to 67 GHz	1.1 dB		1.2 dB
67 to 110 GHz	1.4 dB		1.6 dB
110 to 145 GHz	2.5 dB		NA
Typical return loss (GSG, GSGSG versions only)			
DC to 40 GHz	20 dB		15 dB
40 to 50 GHz	17 dB		15 dB
50 to 67 GHz	16 dB		13 dB
67 to 110 GHz	14 dB		11 dB
110 to 145 GHz	14 dB		NA
Crosstalk	-50 dB @ 50 GHz		Typically -40 dB @ 40 GHz; GSGSG 150 Typically -25 dB @ 40 GHz ; GSSG 150
Electrical repeatability	-60 dB		-60 dB
Probe pitch (25 μ m increments)	50 to 250 μ m pitch (I40, I50 and I67) 50 to 150 μ m pitch (I110)		100 to 250 μ m pitch -
Recommended overtravel	75 μ m		75 μ m
Maximum safe overtravel	150 μ m		150 μ m
Maximum DC current	500 mA (2 A for -HC version) ²		500 mA
Thermal range	-65 to 125°C		-65 to 125°C
Rc on aluminum (gold)	Typically < 0.05 Ω (< 0.02 Ω)		Typically < 0.05 Ω (< 0.02 Ω)
Rc variation during one 5-hour single contact cycle ³	10 m Ω		10 m Ω
Min. probe pad size	25 x 35 μ m (best case)		25 x 35 μ m (best case)

Note: Probe S-Parameter files "s2p" are available at the following [link](#). You will need the exact PN and SN of the probe to download the s2p file.

¹ Signal furthest from ground is not specified for SSG and GSS.

² High-current version (2 A) available up to 67 GHz (GSG only)

³ Specifications applicable at 25°C operating temperature on clean aluminum

See [page 35](#) for recommended Impedance Standard Substrates, and [page 42](#) for a list of cables

[Link to Drawings](#)

Waveguide Infinity Probes

Part Number Key

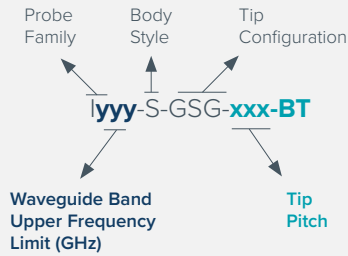

Characteristic	Available values
Waveguide Band	WR15 (50 to 75 GHz), WR12 (60 to 90 GHz), WR10 (75 to 110 GHz), WR8 (90 to 140 GHz), WR6 (110 to 170 GHz), WR5 (140 to 220 GHz), WR3 (220 to 325 GHz), WR2 (325 to 500 GHz)
Body Style	S = Short Waveguide Length and Height, T = Tall Waveguide Length and Height, A = 45° angle connection, No A = Standard horizontal flange connection. See drawing appendix for more detail.
Tip Configuration	GSG
Tip Pitches	50-150 in 25 μm increments (Note: Higher frequencies limit maximum pitch)
Suffix	Blank = Without Bias T, BT = With Bias T

Note: Not all combinations are available.

For each rectangular waveguide designation there are two different probe models.

The "T" models are designed to be compatible with FormFactor's 200 mm and 300 mm systems.

These models are also TopHat™ compatible when used with TopHat PNs 116-441 and 115-164.

The "S" probe models are compatible with FormFactor's 150 mm probing stations.

All models are available without bias network by request.

For older and obsolete probing systems, consult with FormFactor or your local representative for compatibility.

	Body style "T" (tall) & "TA" (tall 45° ang.)	Body style "S" (short) & "SA" (short 45°)
Waveguide designator (Frequency range)		
WR15 (50 to 75 GHz)	I75-T-GSG-xxx-BT I75-TA-GSG-xxx-BT	I75-S-GSG-xxx-BT I75-SA-GSG-xxx-BT
WR12 (60 to 90 GHz)	I90-T-GSG-xxx-BT I90-TA-GSG-xxx-BT	I90-S-GSG-xxx-BT I90-SA-GSG-xxx-BT
WR10 (75 to 110 GHz)	I110-T-GSG-xxx-BT I110-TA-GSG-xxx-BT	I110-S-GSG-xxx-BT I110-SA-GSG-xxx-BT
WR8 (90 to 140 GHz)	I140-T-GSG-xxx-BT I140-TA-GSG-xxx-BT	I140-S-GSG-xxx-BT I140-SA-GSG-xxx-BT
WR6 (110 to 170 GHz)	I170-T-GSG-xxx-BT I170-TA-GSG-xxx-BT	I170-S-GSG-xxx-BT I170-SA-GSG-xxx-BT
WR5 (140 to 220 GHz)	I220-T-GSG-xxx-BT I220-TA-GSG-xxx-BT	I220-S-GSG-xxx-BT I220-SA-GSG-xxx-BT
WR3 (220 to 325 GHz)	I325-T-GSG-xxx-BT I325-TA-GSG-xxx-BT	I325-S-GSG-xxx-BT I325-SA-GSG-xxx-BT
WR2 (325 to 500 GHz)	I500-GSG-xx-BT	
Typical insertion loss / return loss		
I500	8/10 dB (Unique body style, requires chuck riser kit. Consult FormFactor for more info.)	
I325	6.5 dB / 13 dB	5 dB / 12 dB
I220	5.2 dB / 13 dB	4 dB / 13 dB
I170	4.7 dB / 13 dB	4 dB / 13 dB
I140	3.1 dB / 13 dB	3 dB / 13 dB
I110	2.6 dB / 13 dB	2 dB / 13 dB
I90	2.6 dB / 13 dB	2 dB / 13 dB
I75	2.1 dB / 13 dB	1.5 dB / 13 dB
Electrical repeatability	-60 dB	
Probe pitch (25 μm increments)	50 to 100 μm (WR3, WR5, WR6, and WR8) 50 to 150 μm (WR10, WR12, and WR15)	50 to 100 μm (WR3, WR5, WR6, and WR8) 50 to 150 μm (WR10, WR12, and WR15)
Recommended overtravel	25 to 50 μm	
Maximum safe overtravel	100 μm	
Maximum DC current	500 mA	
Thermal range	-65 to 125°C	
Rc on aluminium	Typically < 0.05 Ω	
Rc on gold	Typically < 0.02 Ω	
Rc variation during one 5-hour single contact cycle ¹	10 mΩ	
Minimum probe pad size	25 x 35 μm (best case)	

Note: Probe S-Parameter files "s2p" are available at the following [link](#). You will need the exact PN and SN of the probe to download the s2p file.

¹ Specifications applicable at 25°C operating temperature on clean aluminum.

> Air Coplanar Probes



RF and microwave on-wafer probes: long-lasting, rugged, ACP series

The Air Coplanar Probe was developed in response to the need for a rugged microwave probe with a compliant tip for accurate, repeatable measurements on-wafer. Air Coplanar Probes feature excellent probe-tip visibility and the lowest loss available. For measurements where pad area is at a premium, the ACP family is offered with a reduced contact (RC)¹ area probe tip. The ACP probe family also features dual signal line versions for differential and multiport measurements.

Combining outstanding electrical performance with precise probe mechanics, the ACP probe is the most widely used microwave probe available.

Features

- Unique Air Coplanar tip design
- DC to 110 GHz models available in single and dual line versions
- Low insertion and return loss with ultra-low-loss (-L) versions
- Excellent crosstalk characteristics
- Wide operating temperature -65°C to +200°C
- Wide range of pitches available up to 1250 µm
- Fast delivery available on 100, 125, 150, 200, and 250 µm pitched probes
- Individually supported contacts
- Choice of beryllium copper (BeCu) or tungsten tip material
- Reduced contact (RC) probe tips for small pads
- Precision tip dual configuration available
- BeCu tip provides rugged, repeatable contact on gold pads

¹ For pad sizes smaller than 80 µm, use reduced contact area (RC) tips.

Advantages

- Good visibility at probe tip allows accurate placement on DUT contact-pads
- Outstanding compliance for probing non-planar surfaces
- Stable and repeatable over-temperature measurements
- Typical probe life of 500,000 touchdowns on gold pads
- Reduction in development cycle time

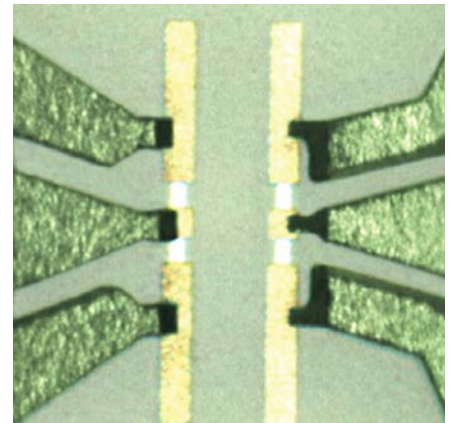

Standard ACP tip (left) versus reduced contact ACP tip (right)

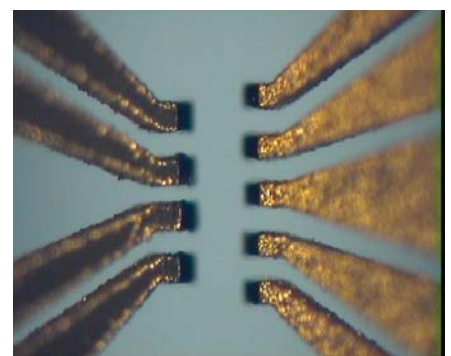

ACP-GSSG (left) vs. ACP-GSGSG (right)

➤ Air Coplanar Probes (Part 1 of 2)

Part Number Key

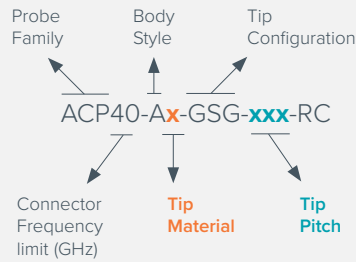

Characteristic	Available values
Coaxial Conn. (Frequency)	40 GHz = 2.92 mm, 50 GHz= 2.4mm, 65 GHz = 1.85mm, 110 GHz = 1mm
Wave Guide	75 GHz, 90 GHz, 110 GHz, 140 GHz, 170 GHz
Body Style - Coaxial and Wave Guide	Blank = Vertical, A = Angled, D = Dual Vertical (Dual angled not avail.), S = Short Wave Guide, T = Tall Wave Guide
Tip Material	Blank = BeCu, W = Tungsten
Tip Configuration	GS, SG, GSG, GSSG, GSGSG
Tip Pitches	50-250 in 25um increments, larger values up to 3 mm may be available (check with factory)
Suffix (Tip modifier)	Blank = Standard tip width (50um), RC = Reduced contact (25um)

Note: Not all combinations are available.

	Probe head type	Part number	Insertion loss Max. (dB) ²	Max DC current ⁵	Max RF power ⁶	MicroChamber compatible	Connector	Recommended ISS	
								Standard (100 to 250 µm)	Wide pitch (250 to 1250 µm)
Single Coaxial	DC to 40 GHz ¹	ACP40-x-GS-xxx	2.0	5 A	6.5 W	Yes	2.92 mm (f)	103-726	106-683
		ACP40-x-SG-xxx	2.0	5 A	6.5 W	Yes		103-726	106-683
		ACP40-x-GSG-xxx	1.0	5 A	6.5 W	Yes		101-190	106-682
		ACP40-Ax-GS-xxx	2.0	5 A	6.5 W	-	2.92 mm (f)	103-726	106-683
		ACP40-Ax-SG-xxx	2.0	5 A	6.5 W	-		103-726	106-683
		ACP40-Ax-GSG-xxx	1.0	5 A	6.5 W	-		101-190	106-682
		ACP40-Lx-GSG-xxx	0.6 ⁴	5 A	6.5 W	-		101-190	106-682
	DC to 50 GHz ¹	ACP50-x-GS-xxx	2.0 @ 40 GHz	5 A	5 W	Yes	2.4 mm (f)	103-726	n/a
		ACP50-x-SG-xxx	2.0 @ 40 GHz	5 A	5 W	Yes		103-726	n/a
		ACP50-x-GSG-xxx	1.4	5 A	5 W	Yes		101-190	
		ACP50-Ax-GS-xxx	2.0 @ 40 GHz	5 A	5 W	-	2.4 mm (f)	103-726	n/a
		ACP50-Ax-SG-xxx	2.0 @ 40 GHz	5 A	5 W	-		103-726	n/a
		ACP50-Ax-GSG-xxx	1.4	5 A	5 W	-		101-190	
		ACP50-Lx-GSG-xxx	1.4	5 A	5 W	-		101-190	
	DC to 65 GHz ¹	ACP65-x-GS-xxx	2.0 @ 40 GHz	5 A	4 W	Yes	1.85 mm (f)	103-726 ³	n/a
		ACP65-x-SG-xxx	2.0 @ 40 GHz	5 A	4 W	Yes		103-726 ³	n/a
		ACP65-x-GSG-xxx	2.0	5 A	4 W	Yes		101-190 ³	
		ACP65-AxGS-xxx	2.0 @ 40 GHz	5 A	4 W	-	1.85 mm (f)	103-726 ³	n/a
		ACP65-Ax-SG-xxx	2.0 @ 40 GHz	5 A	4 W	-		103-726 ³	n/a
		ACP65-Ax-GSG-xxx	2.0	5 A	4 W	-		101-190 ³	
		ACP65-Lx-GSG-xxx	2.0	5 A	4 W	-		101-190 ³	
DC to 110 GHz ^{1,2}	ACP110-Cx-GSG-xxx	1.25	5 A	2 W	Yes	1.0 mm (f)	104-783 ³	n/a	
	ACP110-Ax-GSG-xxx	1.25	5 A	2 W	-		104-783 ³	n/a	
	ACP110-Lx-GSG-xxx	1.15	5 A	2 W	-		104-783 ³		

Note: Probe S-Parameter files "s2p" are available at the following [link](#). You will need the exact PN and SN of the probe to download the s2p file.

Reference Notes:

¹ Angled probes require the 114-592 probe mount for cable clearance.

² Electrical specifications apply to probe pitches of 100 to 250 µm, except for 90, 110 and 140 GHz probes, where the maximum pitch is 150 µm.

³ Use of 116-344 ISS absorber recommended.

⁴ Low-loss probe insertion loss for pitches greater than 150 µm and less than or equal to 250 µm is 0.8 dB

⁵ 2.5 A for W tip, 5 A for BeCu tip, and 1 A for RC tip. All specs are for probe and DUT at room temperature.

⁶ Rated at highest probe frequency. Additionally each probe is capable of > 30W @ 2.4 GHz, > 10W @ 18 GHz, > 7.5W @ 26.5 GHz.

Part Numbers for Reduced Contact Probes

ACP Reduced Contact Probes are available in the same configurations and body styles as the regular ACP series. The standard available pitches are from 100 to 250 µm. Other pitches are available upon request. When ordering, add "RC" to the end of the regular ACP part number from the above, e.g. "ACP40-W-GSG-150RC"

[Link to Drawings](#)

➤ Air Coplanar Probes (Part 2 of 2)

Part Number Key

Probe Family: ACP

Connector Frequency limit (GHz): yy

Body Style: A

Tip Material: x

Tip Configuration: GSG

Tip Pitch: xxx

Tip Configuration modifier: RC

Characteristic	Available values
Coaxial Conn. (Frequency)	40 GHz = 2.92 mm, 50 GHz= 2.4mm, 65 GHz = 1.85mm, 110 GHz = 1mm
Wave Guide	75 GHz, 90 GHz, 110 GHz, 140 GHz, 170 GHz
Body Style - Coaxial and Wave Guide	Blank = Vertical, A = Angled, D = Dual Vertical (Dual angled not avail.), S = Short Wave Guide, T = Tall Wave Guide
Tip Material	Blank = BeCu, W = Tungsten
Tip Configuration	GS, SG, GSG, GSSG, GSGSG (SSG, GSS) ⁴
Tip Pitches	50-250 in 25um increments, larger values up to 3 mm may be available (check with factory)
Suffix (Tip modifier)	Blank = Standard tip width (50um), RC = Reduced contact (25um)

Note: Not all combinations are available.

Probe head type	Part number	Insertion loss Max. (dB)	Max DC current ⁵	Max RF power ⁶	MicroChamber compatible	Connector	Recommended ISS		
							Standard (100 to 250 μm)	Wide pitch (250 to 1250 μm)	
Dual coaxial	DC to 110 GHz ²	ACPyy-Dx-GSGSG-xxx	1.25 @ 40 GHz ³	5 A	2 W	Yes			
		ACPyy-Dx-GSGS-xxx	1.25 @ 18 GHz ³	5 A	2 W	Yes			
		ACPyy-Dx-GSS-xxx	1.0 @ 10 GHz ^{3,4}	5 A	2 W	Yes			
		ACPyy-Dx-GSSG-xxx	1.0 @ 10 GHz ³	5 A	2 W	Yes	User specified	See ISS list (page 35)	
		ACPyy-Dx-SGS-xxx	1.25 @ 18 GHz ³	5 A	2 W	Yes		See ISS list (page 35)	
		ACPyy-Dx-SGSG-xxx	1.25 @ 18 GHz ³	5 A	2 W	Yes			
Waveguide	50 to 75 GHz ²	ACP75-Sx-GSG-xxx	1.5	500 mA	4 W	No	WR-15	104-783 ¹	n/a
		ACP75-Tx-GSG-xxx	2.0	500 mA	4 W	Yes	WR-15		
	60 to 90 GHz ²	ACP90-Sx-GSG-xxx	2.0	500 mA	3 W	No	WR-12	104-783 ¹	n/a
		ACP90-Tx-GSG-xxx	2.5	500 mA	3 W	Yes	WR-12		
	75 to 110 GHz ²	ACP110-Sx-GSG-xxx	2.0	500 mA	2 W	No	WR-10	104-783 ¹	n/a
		ACP110-Tx-GSG-xxx	2.5	500 mA	2 W	Yes	WR-10		
	90 to 140 GHz ²	ACP140-Sx-GSG-xxx	2.5	500 mA	2 W	No	WR-8		
		ACP140-Tx-GSG-xxx	3.0	500 mA	2 W	Yes	WR-8	138-356/357 ¹	n/a

Note: Probe S-Parameter files "s2p" are available at the following [link](#). You will need the exact PN and SN of the probe to download the s2p file.

Reference Notes:

- ¹ Use of 116-344 ISS absorber recommended.
- ² ACP probes, except 110 models, are available in a wide range of pitches from 50 μm to 1250 μm. Insertion loss and frequency performance applies to pitches from 100 to 250 μm, unless otherwise noted. ACP110 probes available in pitches from 100 to 150 μm; minimum pitch for ACP dual probes is 100 μm.
- ³ Insertion loss specification is for a 2.92 mm connectorized probe.
- ⁴ Signal furthest from ground is not specified for SSG and GSS.
- ⁵ 2.5 A for W tip, 5 A for BeCu tip, and 1 A for RC tip. All specs are for probe and DUT at room temperature.
- ⁶ Rated at highest probe frequency. Additionally each probe is capable of > 30W @ 2.4 GHz, > 10W @ 18 GHz, > 7.5W @ 26.5 GHz.

Part Numbers for Reduced Contact Probes

ACP Reduced Contact Probes are available in the same configurations and body styles as the regular ACP series. The standard available pitches are from 100 to 250 μm. Other pitches are available upon request. When ordering, add "RC" to the end of the regular ACP part number from the above, e.g. "ACP40-W-GSG-150RC"

[Link to Drawings](#)

> T-Wave Dual Band Probes

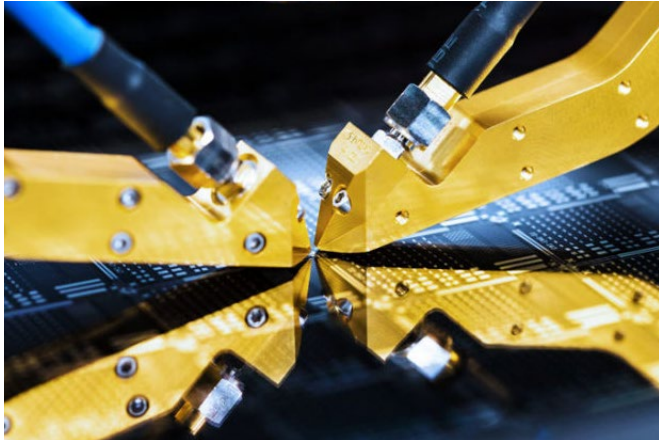

New T-Wave Dual Band Probes Enabling Single-Sweep coverage to 220 GHz

The New T-Wave Dual band Probes sets the industry standard for characterization of ultra broad band needs. This probe delivers low insertion loss and low contact resistance.

T-Wave probes are compatible with FormFactor's Autonomous RF Measurement Assistant, which enables fully autonomous, hands-free RF and mmW calibrations and measurements over multiple temperatures ([page 37](#)).

Features

- Provides for excellent stability and dynamic range
- Low contact resistance
- Probe pitch as narrow as 50 μm
- Lithographically-defined probe tip
- Nickel contacts
- T-Wave probes offer unlimited repairs provided that probe blocks are undamaged

Advantages

- Excellent tip visibility
- One Probe for kHz to 220 GHz in the single sweep
- Saves time on due to no reconfigurations

Part Number	Description
T170-UBBT-GSG-xxx	170 GHz Probe Dual Band with 1 mm connector and WR 6 WG flange
T220-UBBT-GSG-xxx	220 GHz Probe Dual Band with 1 mm connector and WR 5 WG flange

Note: Supported pitches are: 50 μm , 75 μm , 100 μm ,

Exclusively available for use with the following system setup:

- FormFactor Probe systems using RFA probe arms with 45° dual frequency extender mounts
- Keysight 5291A VNA with integral 220 GHz single sweep capability
- Plus the Keysight M4 heads paired with the VDI Mini extended range frequency extenders

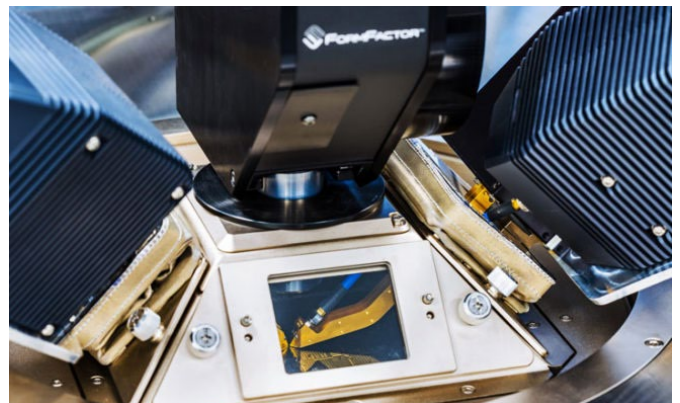

[Link to Drawings](#)

> T-Wave Waveguide Probes



Industry-leading performance for on-wafer measurement of millimeter and sub-millimeter wavelength devices

The T-Wave Probes set the industry performance standard for characterization of mmWave devices. This probe delivers low insertion loss and low contact resistance when probing gold pads.

T-Wave probes are compatible with FormFactor's Autonomous RF Measurement Assistant, which enables fully autonomous, hands-free RF and mmW calibrations and measurements over multiple temperatures [\(page 36\)](#).

Features

- Low insertion loss
- Low contact resistance
- 140 GHz – 11 THz versions
- Probe pitch as narrow as 25 μm
- Lithographically-defined probe tip
- Nickel contacts
- T-Wave probes offer unlimited repairs provided that probe blocks are undamaged

Advantages

- Excellent tip visibility
- Ability to characterize 1.1 THz devices
- Typical Insertion loss < 1.5 dB between 140 and 220 GHz
- Integrated DC bias-T with low-profile GPPO connector

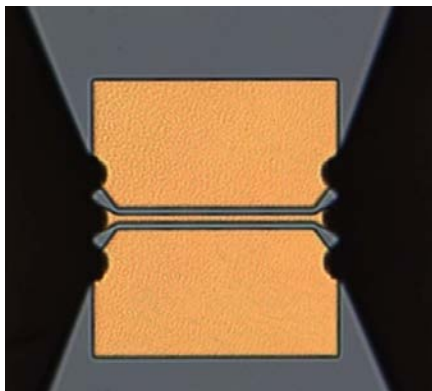

T-Wave Probes contacting a CPW thru line

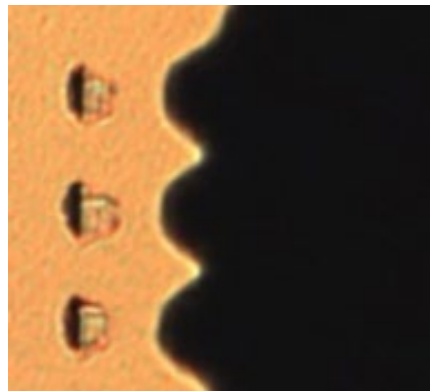

Typical scrub marks of the T-Wave Probes



Autonomous RF Measurement Assistant with T-Wave Probes

[Link to Drawings](#)

T-Wave Probes

Part Number Key

Probe Family

Body Style

Tip Configuration

Waveguide Band Upper Frequency Limit (GHz)

Tip Pitch

Tyyyy-S-GSG-xxx-BT

Characteristic	Available values
Waveguide Band	WR5.1 (140 to 220 GHz), WR4.3 (170 to 260 GHz), WR3.4 (220 to 330 GHz), WR2.2 (325 to 500 GHz), WR1.5 (500 to 750 GHz), WR1.0 (750 to 1.1 THz)
Body Style	S = Short Waveguide Length and Height, T = Tall Waveguide Length and Height
Tip Configuration	GSG
Tip Pitches	See table below
Suffix	BT = With Bias T

Note: Not all combinations are available.

The 220, 260, and 330 GHz waveguide probes come in two different models. The "T" body style is compatible with FormFactor's 200 mm and 300 mm probe stations, including most legacy products. The "S" body style is compatible with FormFactor's 150 mm probe stations. All models are available without bias-T by request.

	Body Style "T"	Body Style "S"
Waveguide designator (Frequency Range)		
WR5.1 (140 GHz – 220 GHz)	T220-T-GSG-xxx	T220-S-GSG-xxx
WR4.3 (170 GHz – 260 GHz)	T260-T-GSG-xxx	T260-S-GSG-xxx
WR3.4 (220 GHz – 330 GHz)	T330-T-GSG-xxx	T330-S-GSG-xxx
WR2.2 (325 GHz – 500 GHz)	N/A	T500-S-GSG-xx
WR1.5 (500 GHz – 750 GHz)	T750-GSG-25 (Low profile probe)	
WR1.0 (750 GHz – 1.1THz)	T1100-GSG-25 (Low profile probe)	
Typical Insertion Loss / Return Loss		
T1100	7 dB / 15 dB	
T750	5 dB / 15 dB	
T500	N/A	4.5 dB / 15 dB
T330	4.3 dB / 15 dB (typical)	2.9 dB / 15 dB (typical)
T260	3.2 dB / 15 dB (typical)	2.2 dB / 15 dB (typical)
T220	2.3 dB / 15 dB (typical)	1.5 dB / 15 dB (typical)
Probe pitch (25 µm increments)	25 µm (WR1.0 and WR1.5) 25 µm, 50 µm (WR2.2) 25-100 µm (WR3.4, WR4.3, WR5.1)	25 µm (WR1.0 and WR1.5) 25 µm, 50 µm (WR2.2) 25-100 µm (WR3.4, WR4.3, WR5.1)
Recommended overtravel	10 µm (Au) 25-35 µm (Al)	10 µm (Au) 25-35 µm (Al)
Maximum safe overtravel	60 µm	
Maximum DC current	500 mA	
Rc on Al	Typically < 0.30 Ω	
Rc on Au	Typically < 0.04 Ω	
Rc variation during one 5-hour single contact cycle	N/A	
Minimum probe pad size	25 x 40 µm for passivation windows, 15 x 15 µm for Au with no passivation (both best cases)	25 x 40 µm for passivation windows, 15 x 15 µm for Au with no passivation (both best cases)

Note: T-Wave® Probes with undamaged probe blocks are eligible for an unlimited number of repairs.

[Link to Drawings](#)

> IZI Probes



Oblique Body



Dual Body



Single Standard Body



Slim Body

IZI Probes for RF/Microwave Applications

The IZI Probe® patented technology used in the IZI Probe assures high-accuracy measurements with low contact resistance and superior impedance control. The RF/Microwave signal makes only one transition to the coplanar contact structure within the shielded, air-isolated probe body, maintaining signal integrity at temperatures as low as 4 K, or as high as 300°C. This capability makes the IZI probe suitable for the harshest test environments, from cryogenic test and measurement to characterize future computing ICs to high temperatures in closed systems for applications such as automotive devices.

Contacting the device under test (DUT) with the IZI Probe is simple, highly repeatable and requires significantly less overtravel than alternative RF wafer probes. This is due to the robust design of the coplanar contact structure and the elimination of micro-coax cable. Additionally, the contacts can move independently of one another, which allows you to probe on three-dimensional structures and on wafers with pad-height deviation of up to 50 µm.

For differential, cryogenic, multi-port and mixed-signal applications, the Dual IZI Probe and Multi-IZI Probe are available.

The 1MX™ Technology is an enhancement to the IZI Probe family of RF and microwave wafer probes. It is based on a significant miniaturization of the CPW (coplanar waveguide) structure which leads to a higher bandwidth capability and better electrical performance by keeping in parallel the unique IZI Probe advantages like robustness, contact quality, and repeatability

Features/Benefits:

Durability

- Incredibly long lifetime (typically > 1,000,000 touchdowns on Al pads)
- Unparalleled repeatable and reliable contact quality
- Suitable for automated testing

Flexibility

- Probe on most pad material with minimal damage
- Independent, contact springs easily overcome pad height differences up to 50 µm
- Small structures such as 40 µm x 40 µm pads can be tested
- Excellent performance in vacuum and cryo environments and temperatures from 10 K to 300°C, using the cryo / vacuum versions (see [page 31](#) for more details on cryo)
- Multiple body styles are available as seen in pictures above

RF performance

- Excellent RL and IL performance over specified range achieved via excellent impedance control with perfectly symmetrical coplanar contact structure eliminating signal distortion
- Low contact resistance achieved with MEM's nickel contacts
- 1MX technology ensures low insertion loss, high isolation and accurate measurements
- High Power Versions for you RF power measurement needs

[View Family Overview](#)[Link to Drawings](#)

> IZI Probes

Part Number Key

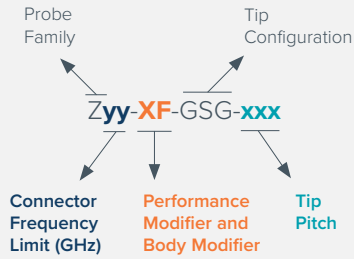

Characteristic	Available values
Coaxial Conn. (Frequency)	4 GHz = 3.5 mm Connector, 10, 20 & 40 GHz = K-Connector, 50 GHz = 2.4 mm, 67 GHz = 1.85 mm (all Female)
Performance Modifier and Body Modifier	Blank = Classic, X = 1MX, V = Vacuum, D = Dual, B = PCB, F = Slim, P = Power, R = Right Oblique, L = Left Oblique (Note: Not all of these parameters can be combined. Contact your sales representative for more information.)
Tip Configuration	GS, SG, GSG, GSSG, GSGSG
Tip Pitches	50-250 in 25 μm increments, larger values may be available (check with factory)
Suffix (Tip modifier)	Blank = Standard microstrip version, HC = High-current version (CPW tip structure)

Note: Not all combinations are available.

Probe Type	Frequency	Connector	Configuration	Standard Pitch	Typical Application / Instrumentation
IZI Probe (Classic)	DC-10 GHz	2.92 mm	GS, SG	100-1250 $\mu\text{m}^{1,2}$	Single signal probe, S parameter, TDR, spectrum analysis, oscilloscope
IZI Probe (Classic)	DC-40 GHz	2.92 mm	GSG	100-1250 $\mu\text{m}^{1,2}$	
IZI Probe (1MX)	DC-20 GHz	2.92 mm	GS, SG	50-500 $\mu\text{m}^{1,2}$	
IZI Probe (1MX)	DC-40 GHz	2.92 mm	GSG	50-500 $\mu\text{m}^{1,2}$	
IZI Probe (1MX)	DC-50 GHz	2.4 mm	GSG	50-500 $\mu\text{m}^{1,2}$	
IZI Probe (1MX)	DC-67 GHz	1.85 mm	GSG	50-250 $\mu\text{m}^{1,2}$	
IZI Probe Dual (Classic)	DC-10 GHz	2.92 mm	GSSG, SGS	100-250 + 500 $\mu\text{m}^{1,2}$	Dual signal probe, differential or multilane S parameter, TDR, spectrum analysis, oscilloscope
IZI Probe Dual (Classic)	DC-40 GHz	2.92 mm	GSGSG	100-250 + 500 $\mu\text{m}^{1,2}$	
IZI Probe Dual (1MX)	DC-20 GHz	2.92 mm	GSSG, SGS	100-250 + 500 $\mu\text{m}^{1,2}$	
IZI Probe Dual (1MX)	DC-40 GHz	2.92 mm	GSGSG	100-250 + 500 $\mu\text{m}^{1,2}$	
IZI Probe Dual (1MX)	DC-50 GHz	2.4 mm	GSGSG	100-250 + 500 $\mu\text{m}^{1,2}$	
IZI Probe Power (Classic)	DC-40 GHz	2.92 mm	GSG	100-500 $\mu\text{m}^{1,2}$	Single signal probe, high RF power or low loss, S parameter, loadpull, noise parameter
IZI Probe PCB (see page 30)	DC-4/20 GHz ³	3.5 mm	GS, SG, GSG	500-2500 μm^4	Single signal probe, signal integrity, S parameter, TDR, spectrum analysis, oscilloscope

¹ Pitches outside the listed standard range are available. Contact your local sales representative for more information.

² Pitches in the range of 50 to 200 μm are generally available in 25 μm increments, and pitches above 200 μm are generally available in 50 μm increments.

³ Able to support frequencies up to 20 GHz for GSG configurations in some cases. Contact your local sales representative for more information.

⁴ Available pitches for IZI Probe PCB: 500, 650, 800, 1000, 1250, 1500, 2000, 2500 μm

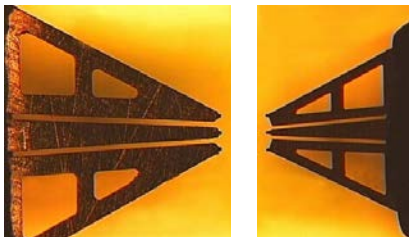

Comparison of Classic to 1MX IZI Probe tips

[Link to Drawings](#)

> Multi-contact RF Probes



InfinityQuad Probe

For repeatable and precise engineering tests of DC, logic, RF and mmWave RFIC devices, InfinityQuad probe, the first configurable multi-contact probe, ensures reliable measurement results up to 110 GHz over a wide temperature range. The photo-lithographically defined fine-pitch tip structure enables probing of small pads down to 30 x 50 μm with minimum pad damage and consistent low contact resistance. The durable probe tips ensure more than 250,000 touchdowns on Al pads and Au pads, and provide accurate X, Y and Z alignment.

For more details, visit www.formfactor.com/products/probes/infinityquad and use our [online tool to capture your design](#) requirements and receive a quote.

Features

- Customizable configuration up to 25 contacts: RF, Eye-Pass power, ground, logic
- *NEW* Custom and variable pitches are available up to a maximum probe face width of 6 mm
- Fine-pitch probe tips enables probing of pitches as small as 70 μm and 30 x 50 μm pads
- Low and repeatable contact resistance on aluminum pads (< 0.05 Ω) ensures accurate results
- Durable probe structure ensures more than 250,000 contacts

- Intuitive design capture tool ensures accurate design and fast product delivery

Specifications

- Number of contacts: From 4 to 25
- Number of 'Premium' channels: Up to 4 Premium channels (40, 50, 67 or 110 GHz)
- Standard available contact pitches: 70, 75, 80, 90, 100, 125, 150, 200 and 250 μm
- Custom and variable pitches available
- Tip material: Non-oxidizing nickel alloy tips

- Minimum pad size: 30 x 50 μm (see Pad layout rules for details)
- Contact area: 12 x 8 μm (nominal)
- Operating temperature: -40°C to +125°C (max. -55°C to +150°C)
- Contact life: > 250,000 touchdowns
- Recommended overtravel: 50 - 75 μm
- Maximum safe overtravel: > 250 μm
- Maximum DC current: 400 mA
- Maximum DC voltage: 50 V power bypass (100 V other)
- Series resistance (not including contact): < 2 Ω

Note: Custom and variable pitches will have longer lead times

Performance:

Typical performance for GSG 100 μm RF Lines

Insertion loss

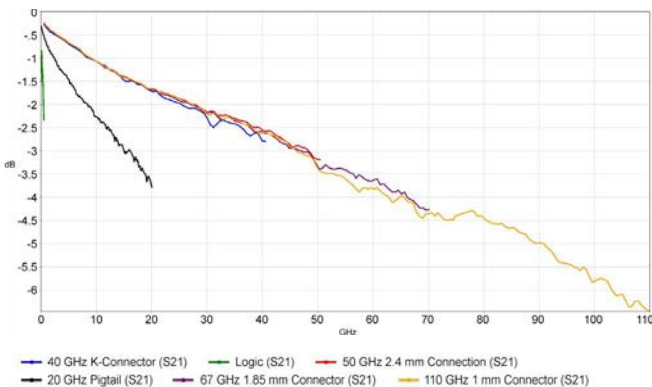

Return loss

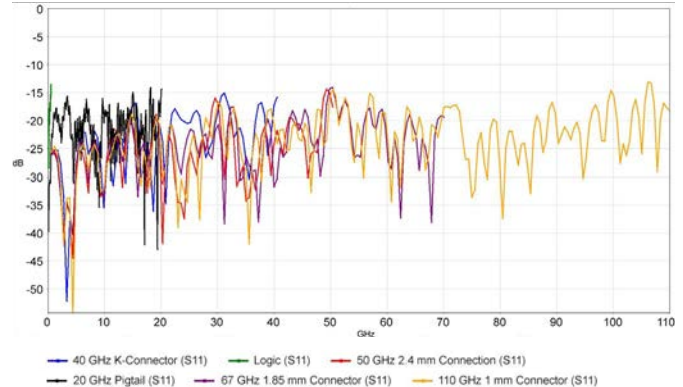

[Link to Drawings](#)

> Multi-contact RF Probes



Unity Probe

The multi-contact Unity Probe provides highly flexible configurability, unprecedented durability and ease-of-use for RFIC engineering test. Unlike “bent-to-order” needle-probe solutions, Unity Probes are quickly “built to order” with a precision tip cluster featuring multiple independently compliant fingers to isolate chip components from probing stresses — maximizing probe life and durability. Each contact can be configured to one or several contact types and frequencies, and the Unity Probe delivers on the legendary quality you’ve come to expect from FormFactor’s comprehensive suite of probing solutions.

Features

- Up to 12 contacts; any contact can be DC, Power, Logic to 500 MHz, or RF to 20 GHz
- Online design configuration tool helps you to specify your probe in minutes
- All designs are fully quadrant compatible
- Full solution includes probes, calibration substrates, stations, accessories and calibration software
- Scalable architecture for future needs

Electrical

- Maximum DC current: 1 A
- Maximum DC voltage: 50 V power bypass (>100 V other)
- Series resistance (not including contact): < 0.2 Ω
- Rc on aluminum at 25°C: < 0.1 Ω
- RF connector: Gore 100 series
- DC/Logic connector: Two 0.025 inch square pins on 0.100 inch pitch
- Eye-Pass bypass inductance: 0.4 nH

Mechanical

- Number of contacts: 3 to 12 (Missing contacts count toward max.)
- Available contact pitch: 100 to 250 μm (25 μm steps)
- Tip material: Beryllium copper (BeCu) or tungsten (W)
- Contact area: 50 x 50 μm (nominal)
- Contact life > 250 k touchdowns on aluminum pads, > 500 k touchdowns on gold pads

Sample Configuration:

P'PGXLG'PP'G

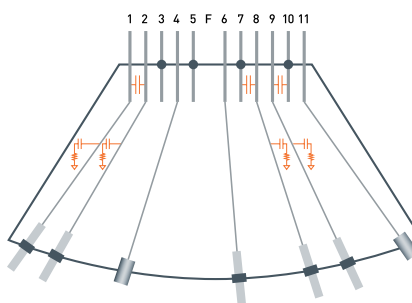

. = Ground connection
450 pF to adjacent finger
10 nF and 2.7 Ω to Ground

Ordering Information

See [Unity Probe product page](#) to create a configuration code.

Optional cables available

P/N 147-295
SMA Female to square pin 8 in.
(20 cm) flex cable

P/N 147-364
2.92 mm Female to Gore 100 8 in.
(20 cm) flex cable

[Link to Drawings](#)

> Multi-contact RF Probes

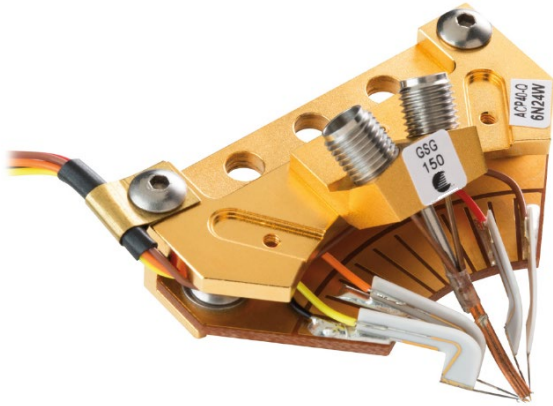

ACP Quadrant Probes

Quadrant Probes were developed in response to the need for multiple probe tips in a single module. Configurations consist of all RF or a combination of RF and DC.

The RF probes use Air Coplanar technology to produce a rugged microwave probe with a compliant tip for accurate, repeatable measurements on-wafer. The DC probes use ceramic blade needles for low noise and high performance.

The ACP Quadrant Probes are customizable to fit your specific needs. Please contact us for available options and possible configurations.

Features

- Combination of DC and RF in a single probe module: One dual probe or a maximum of three separate RF. Maximum of 9 DC standard (other quantities upon request).
- Utilizes ACP tip design, GSG, GS, SG, GSSG, or GSGSG
- RF tips available from DC to 110 GHz
- Choice of BeCu or tungsten tips
- DC power needles come standard with 100 pF microwave capacitor
- Power bypass inductance: 8 nH
- Max. DC voltage: 50 V without power bypassing (25 V with standard power bypassing, and component dependent with custom power bypassing)

For design boundary conditions, contact FormFactor.

Advantages

- Ideal for probing the entire circuit for functional test
- Dual ACP configuration supports differential signaling applications
- DC probes can provide power or slow logic to circuit under test

Configuration Boundaries

- Configuration limitations are layout dependent. Consult with your field sales or application engineer for more details.
- Adjacent probe compatibility. Once FormFactor receives your requested configuration and DUT layout details, we will model for compatibility/potential collisions.
- When separate RF lines are used, the minimum signal to signal spacing is 1200 μm (this limitation does not apply to dual probe versions).

Ordering Information

See [ACP Quadrant Probe design capture form](#) to learn how to create a configuration code

[Link to Drawings](#)

> IZI Probes



Multi-IZI Probe

Accurate multi-contact probes with long lifetime for multiport and digital signal testing. Based on the durable IZI Probe design, Multi-IZI Probes allow up to 35 mixed-signal contacts on one probe, with optional on-board components. The Multi-IZI Probe can also be integrated into the QuadCard™ for high-throughput RF testing.

Features

- Mix DC and RF/Microwave contacts
- Long lifetime (typically > 1,000,000 touchdowns)
- Contact types: RF, Power, Logic, and Ground
- Contact size: 35 μm wide
- The Multi-IZI Probe is the only RF probe that can be configured with up to 16 RF channels (35 contacts), providing you with unparalleled multiport RF measurement capabilities up to 15 GHz and superior broadband digital measurements up to 25 GHz.
- Option of placing DC lines on unused RF contacts. This means you can measure DC and RF signals on one very accurate probe, eliminating the need for costly probe cards in many applications.
- Excellent performance in temperatures ranging from 10 K to 300°C
- High performance low impedance power line and bypassing networks for power supply connections
- Probe on any pad material with minimal damage
- Multiple DC and high performance RF connector options
- Multiple sizes based on number of contacts
- Shunts, baluns, DC-blocks or even circuits can be placed directly on the probe with customization options.
- Pitches from 100 μm to 500 μm are standard, other pitches and individual configurations on request.
- Part of a complete solution for multiport RF wafer level testing along with FormFactor probe systems, which offer the highest positioning
- This comprehensive solution provides the highest possible accuracy and flexibility in on-wafer HF testing for production and development accuracy in X, Y, and Z - a vital feature for HF probing.
- The technology used in the Multi-IZI Probe is similar to that of all IZI Probes. Contact resistance on gold and aluminum is extremely low, and the Multi-IZI Probe's independent, contact springs can overcome pad height differences of up to 50 μm while providing stable contact and an extremely long lifetime.
- The RF signal is transmitted from the connector to the air-coplanar waveguide (CPW) lines across an RF-PCB board. Furthermore, the MEMS-machined, symmetrical structures of the Multi-IZI Probe keep coupling and crosstalk at a low level.

Ordering Information

See [Multi-IZI Probe design capture form](#) to create a configuration code.

Probe Type	Frequency	Configurable	Non-Uniform Pitch	Number of Contacts
Multi-IZI Probe	DC – 25 GHz ²	Yes	Yes	Up to 35 contacts; can be customized for larger quantities

¹ Specific criteria and conditions apply. 300°C for cryo version and 200°C for standard version. Contact your local Applications Support for more information.

² Maximum RF bandwidth is pitch and configuration dependent.

[Link to Drawings](#)

> Multi-contact DC Probes



Eye-Pass Probe

The Eye-Pass multi-contact DC probe is designed to provide a multitude of simultaneous connections to a wafer or similar devices. The connections may be ground, logic/signal, standard power and Eye-Pass power. For power-supply connections, Eye-Pass high-performance power-bypass technology delivers low impedance and resonance-free power connections over an extremely wide frequency range. Used with ACP-series probes and/or multi-contact RF Unity Probes, Eye-Pass probes provide functional at-speed testing for Known-Good-Die. Customized for the user-selected footprint that best suits your application, Eye-Pass probes feature up to 12 contacts per probe head, precisely aligned in a highly durable precision tip cluster to provide high compliance.

Features

- High-performance power bypassing for low-impedance and oscillation-free testing to more than 20 GHz
- Mix multiple contact types: Ground, Power (Standard or Eye-Pass), Logic/Signal
- Low and repeatable contact resistance on aluminum pads ($< 0.25 \Omega$ on Al, $< 0.01 \Omega$ on Au)
- Long probe life with more than 250 k touchdowns for moderate volume production test

Electrical

- Maximum DC current: 1 A
- Maximum DC voltage: 50 V power bypass (>100 V other)
- Series resistance: $< 1 \Omega$ (not including R_c)
- Connector: 2 x 12 square pin header (ground row furthest from tip), Direct mapping of connector pins to contacts (no custom routing)
- Eye-Pass bypass inductance: 0.4 nH

Mechanical

- Number of contacts: 2 to 12 (Missing contacts count toward max.)
- Available contact pitch: 100 to 250 μm uniform spacing
- Tip material Beryllium copper (BeCu) for gold pads (Au) or tungsten (W)
- Contact area: 50 μm x 50 μm (nominal)
- Contact life > 250 k touchdowns on aluminum pads, > 500 k touchdowns on gold pads

Sample Configuration:

P'PGXLG'PP'G

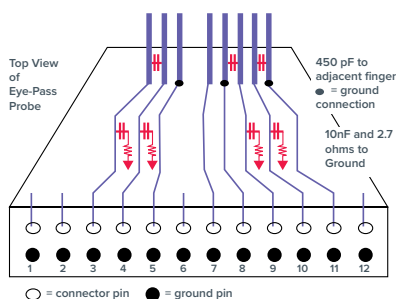

Conn Pin number	Contact	Type
1		No Contact
2		No Contact
3	P	Eye-Pass Power ¹
4	P	Eye-Pass Power
5	G	Ground
6	X	No Contact
7	L	Logic/Signal
8	G	Ground
9	P	Eye-Pass Power
10	P	Eye-Pass Power
11	G	Ground
12		No Contact

¹ Adjacent ground recommended for best Eye-Pass Power performance

Ordering Information

See [Eye-Pass Probe product page](#) to create a configuration code.

Optional cables available

P/N 124-082

BNC Male to 2 pin Molex connector cable, 4ft length (single channel)

[Link to Drawings](#)

> Multi-contact DC Probes

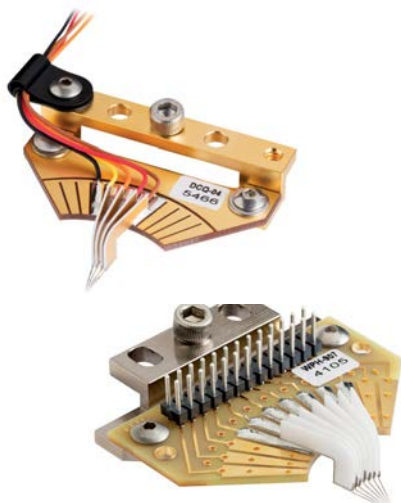

Multiple configurations for functional circuit testing

The DCQ probes use controlled impedance, ceramic blade needles for low noise and high performance (up to 24 contacts). This needle style allows the placement of high-quality bypass capacitors with very little series inductance due to their close proximity to the probe tip. All of the needles are connected to a common ground plane but individual needles can be easily (ground) isolated for additional low noise performance. These probes also feature integrated cabling with several options.

The WPH probes feature up to 12 ceramic-bladed, nickel-plated, tungsten needles with a 2 x 12 square pin cable interface. The circuit board has been laid out such that both series and shunt components can be added to the signal path of each needle.

Features

- Customized to customer application
- DCQ capable of up to 24 DC contacts
- WPH capable of up to 12 DC contacts
- Standard DCQ probes have flat tip needles available in nickel-plated tungsten or BeCu with diameters of 0.75 mil, 1.0 mil and 1.5 mil. WPH probes have full-radius, nickel-plated tungsten needles.
- DCQ supports collinear and non-standard needle configurations
- Power bypass inductance: DCQ 8 nH, WPH 16 nH
- DCQ's come standard with header pin cable harness and optional Banana, BNC, SMA, and Triax cabling are available

Advantages

- Ideal for probing the entire circuit for functional test
- DC probes can provide power or slow logic to circuit under test

Ordering Information

See [DCQ Probe design capture form](#) to create a configuration code.

See [WPH Probe design capture form](#) to create a configuration code.

Probe head type	Part number (yy= number of DC probes)	Max. number of DC probes	MicroChamber compatible	Connector
DCQ Quadrant Probe ⁶ custom version up to 24 ¹	DCQ-yy	24	Yes ⁵	DCQ DC connections are supplied via a wire pig-tail to square pin header, standard. ²
WPH needle probe heads	WPH-9yy-xxx ³ WPH-9yy-NS ⁴	12 12	No No	Circuit board mounted square-pin header, standard.

Notes:

¹ Use Quadrant Probe Design Capture Form to specify number of DC needles and layout of DC lines.

² Custom coax and triax cabling and/or connectors are available.

³ The -xxx suffix indicates probe contact center-to-center spacing (pitch) in microns, e.g. WPH-908-150 has 8 needles with a spacing of 150 μm (5.91 mils). Needles are in collinear pattern with constant pitch.

⁴ Needles may be configured in a non-standard array and/or custom bypass components mounted on PCB. Standard bypass capacitor is rated at 10 V, higher voltage ratings are available.

⁵ MicroChamber compatibility up to 12 needles.

⁶ Maximum voltage is 50 V without power bypassing, 25 V with standard power bypassing (10 V for WPH probes), and component dependent with custom power bypassing option.

[Link to Drawings](#)

> Board Test and Signal Integrity Probes



Fixed-Pitch Compliant Probe (FPC)

The FPC-Series (Fixed-Pitch Compliant) is a high-frequency 50 Ω coaxial probe that offers a signal line with either one or two low-inductance fixed-pitch ground contacts. The probe tip structure is lithographically defined for unsurpassed impedance control, preserving the highest integrity possible when launching and receiving signals from SMT boards, hybrids and multi-chip modules (MCM).

Features

- DC to 40 GHz bandwidth
- Maximum DC current: 5 A
- 10 ps rise time
- Low insertion and return loss
- 2 mils of tip-to-tip compliance
- High probing angle and clearance
- High-power handling capability

Advantages

- Maintains 50 Ω environment which allows accurate high-frequency measurement of microelectronic modules
- Compliant tips allow probing of non-planar structures
- BeCu tips provide longer probing life and reduce probe damage
- Access contacts close to components, module walls, or other obstructions

Probe head type	Part number ^{1,2,3}	Insertion loss, typical	Return loss min.	Connector & tip type	Recommended cable	Recommended ISS (100 to 250 μm)	Wide pitch (250 to 1250 μm)
DC-40 GHz ^{4,5}	FPC-GS-xxx	2.0 dB	10 dB	BeCu. 2.92 mm (f)	124-084-B	103-726	106-683
	FPC-SG-xxx	2.0 dB				103-726	106-683
	FPC-GSG-xxx	1.0 dB				101-190	106-682
DC-40 GHz ^{4,5}	FPC-W-GS-xxx	2.0 dB	10 dB	Tungsten 2.92 mm (f)	124-084-B	103-726	106-683
	FPC-W-SG-xxx	2.0 dB				103-726	106-683
	FPC-W-GSG-xxx	1.0 dB				101-190	106-682

Notes:

¹ The -xxx suffix indicates probe contact center-to-center spacing (pitch) in microns, e.g. FPC40-SG-150 is 150 μm (5.91 mils). Contacts are on a constant pitch and width is approximately 50 μm .

² The convention for describing probe head footprints is the sequence of contacts as seen looking down on the probe head tip in its functional position, with the tip pointing away from the viewer, describing contacts from left to right.

³ FPC standard pitches are 100, 125, 150, 200, 250, 350, 500, 650, 750, 1000 and 1250 μm . Non-standard pitches are available from 100 μm to 1250 μm and by special order to 3000 μm . Insertion loss applies to standard pitch range. Other pitches may have increased insertion loss. Adapter 106-835 is required for Summit Series positioners.

⁴ FPC GSG probes: 40 GHz up to 250 μm pitch, 20 GHz up to 1250 μm pitch and 3 GHz up to 3000 μm pitch. FPC GS/SG probes: 40 GHz up to 250 μm pitch, 18 GHz up to 500 μm pitch, 10 GHz up to 1250 μm pitch and 3 GHz up to 3000 μm pitch.

⁵ FPC probes are not designed for use with MicroChamber probing stations.

⁶ Use the standard RF mount to FPC adapter (P/N 104-913).

[Link to Drawings](#)

➤ Board Test and Signal Integrity Probes

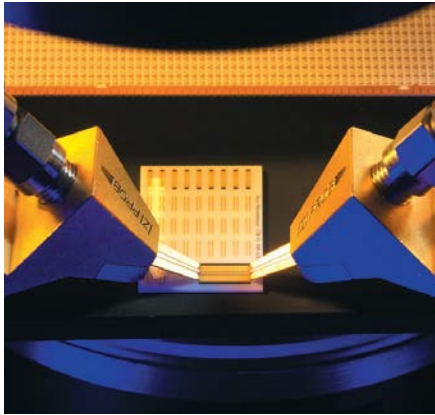

IZI Probe PCB

The FormFactor IZI Probe PCB is an inexpensive alternative to costly test fixtures and it is especially suitable for production test. A revolutionary tip enables an extremely precise and safe contact with a planar-planar contact on PCBs, ICs and ceramic substrates up to 4 GHz. Custom probes can be supplied up to 20 GHz. Fully 50 Ω impedance matched, the HF transmission is totally isolated by air, ensuring the lowest possible insertion loss. A robust design makes the IZI Probe PCB easy to handle and guarantees a long working life. No other probe can withstand such high voltages and power (up to 30 watts).

Mechanical Specifications

Electrical Characteristics (50 GHz GSGSG)

• Characteristic impedance	50 Ω
• Frequency range	DC to 4 GHz (20 GHz on request)
• Return loss	≤ -27 dB DC to 4 GHz
• Insertion loss	≤ -0.25 dB DC to 4 GHz
• RF maximal power	30 W
• Contact resistance on Au	$\leq 0.1\Omega$

Mechanical characteristics

• Contact Material	Stainless steel with gold plating
• Insulator	PEEK
• Contact cycles	$\geq 50,000$
• Contact width	0.2 mm
• Contact pressure (GSG)	3 N (Recommended)
• Contact pressure (GS)	2 N (Recommended)
• Standard pitches	500 μm , 650 μm , 800 μm , 1000 μm , 1250 μm , 1500 μm , 2000 μm , 2500 μm (others on request)
• Type	PC 3.5, female
• Coupling torque	0.8 to 1.1 Nm (Recommended)
• Outer contact	Stainless steel
• Center contact	CuBe with Au plating
• Insulator	PS

Environmental Data

• Temperature range	-65°C to 125°C
---------------------	----------------

[Link to Drawings](#)

> Special Purpose Probes



Cryogenic RF and Mixed Signal Probes

The probes that you use in your cryogenic environment are critical to the performance you can achieve with your cryogenic system. This is because they are in direct contact with your DUT, which you are trying to reach and hold at very specific low temperatures. Anything in direct contact with your DUT is a potential heat source directly coupled to your DUT, so care must be taken to minimize its impacts. FormFactor offers several Rf and Mixed signal probes, that have been optimize where possible for use in your Cryogenic environment. This helps with both the speed of reaching your desired temperature and ultimate temperature achievable.

What do we optimize?

- Material used
- Connectors
- Tip materials
- Thermal mass (minimize)

Features

Temp range 77 K to 300° C (customer have used to 4 K)

Versions (most standard versions of IZI and Multi-IZI probes can be built in cryogenic versions)

See [page 21](#) and [page 26](#) for available types and spec's.

Note Order Body type VF (V=Vacuum/ F=Slimbody)

Products

- Slim Z cryo probes (lowest overall thermal mass)
- Dual Z cryo probes
- Multi-IZI probes (multiple size, configurations and connector types available)
- ACP Series (limited configurations available)



>Special Purpose Probes



Light Wave Probe

The LWP series of lightwave probes enable optical measurements for on-wafer and hybrid photonics devices. It features user-replaceable fiber pigtailed allowing the probe to be optimized for a variety of light delivery and light collection applications including the characterization of topside illuminated photodiodes, Vertical Cavity Surface Emitting Lasers (VCSELs), hybrid transmitters and receivers, and LEDs.

Features/Benefits:

Flexibility and ease of use

- Field-replaceable fibers optimized for a variety of applications
- Wafer mapping capability and visual display of key parameters

Accuracy

- Patented contact protection design ensures fast, accurate, and repeatable measurements at the wafer and substrate level
- Minimized electrical parasitics for at-speed testing

Compatibility

- Standard FC type fiber-optic connector
- Compatible with FormFactor probe stations and accessories

Specifications

Fiber Type	Minimum Illumination Diameter	Wavelength	Numeric Aperture	Insertion Loss
Cleaved single-mode (CLV-SM)	25 μm	1300 nm, 1550 nm	0.13	0.5 dB
Cleaved multi-mode (CLV-MM)	100 μm	850 nm – 1550 nm	0.28	0.5 dB
Lensed single-mode (LEN-SM)	5 μm	1300 nm, 1550 nm	NA	0.5 dB
Lensed multi-mode (LEN-MM)	50 μm	850 nm – 1550 nm	NA	0.5 dB

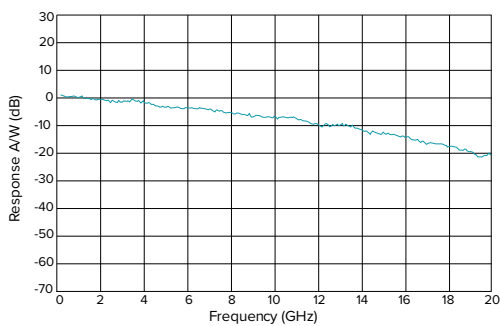

Responsivity measurement of an 80 μm photodiode using the LWP probe and the Agilent Technologies 83420A Lightwave Test Set.

>Special Purpose Probes



Termination and Resistive Matching Probe

FormFactor offers a wide range of resistive matching or termination probes in ACP, Infinity and FPC product lines in both single and dual versions. With a range of series resistive matching values from 10 ohms to 1 k ohms. 50 Ohm Termination probes are offered as well. These matching and termination probes use high performance RF resistors with the resistor mounted as close as possible to the probe contact.

Example Applications:

- Termination
- TLP (transmission line pulse)
- Matching

Performance

These types of probes are custom with limited testing

Termination Probes:

For probes that have the full RF connection path the typical recommended usable frequency range is 6-10 GHz. This limit is due to the parasitic capacitance of the high-performance RF resistor.

Resistive Matching Probes:

Adding series resistor to the probe leaves FormFactor with no way to calibrate or validate the RF performance. This is because no calibration standards exist, so the RF performance is purely best effort. The typical recommended usable frequency range is 6-10 GHz.

Testing Methodology

For probes that have the full RF connection path, they are built and tested as standard RF probes first, and then the Resistor is added. After adding the resistor only DC resistance measurement are performed. For versions with no RF connector/s only DC resistance measurements are performed.

Due to the location and size of these resistors they are low power typically 125mw, however a limited number of higher power version are available.

Contact your local sales representative or applications engineer for more details

Single Signal Line Versions

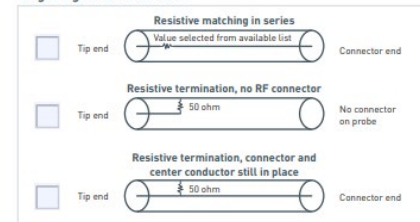

Dual Signal Line Versions

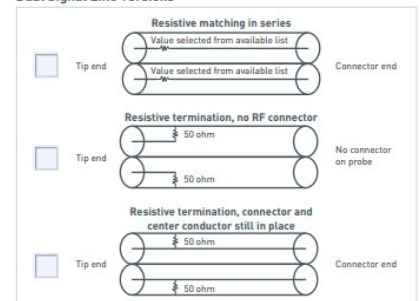

Supporting Software

WinCal XE™

WinCal XE software from FormFactor is a comprehensive and intuitive on-wafer RF measurement calibration tool to achieve accurate and repeatable S-parameter measurement, which is crucial for precision device modeling/ characterization and engineering RFIC test.

The WinCal XE features a guided system setup complete with customizable Wizards to ensure fast and easy access to reliable VNA calibration and repeatable data. Automated and intelligent functions minimize operator errors and troubleshooting time, resulting in reliable and accurate results and higher productivity.

The WinCal XE features include exclusive 1-, 2-, 3-, and 4-port calibration algorithms, immediate and live data measurement and viewing, LRRM™, LRM+™, SOLT, SOLR, hybrid LRRM-SOLR and NIST-style multi-line TRL calibrations, as well as an Error Set Management capability for data comparison and augmentation.

[View WinCal XE Datasheet](#)

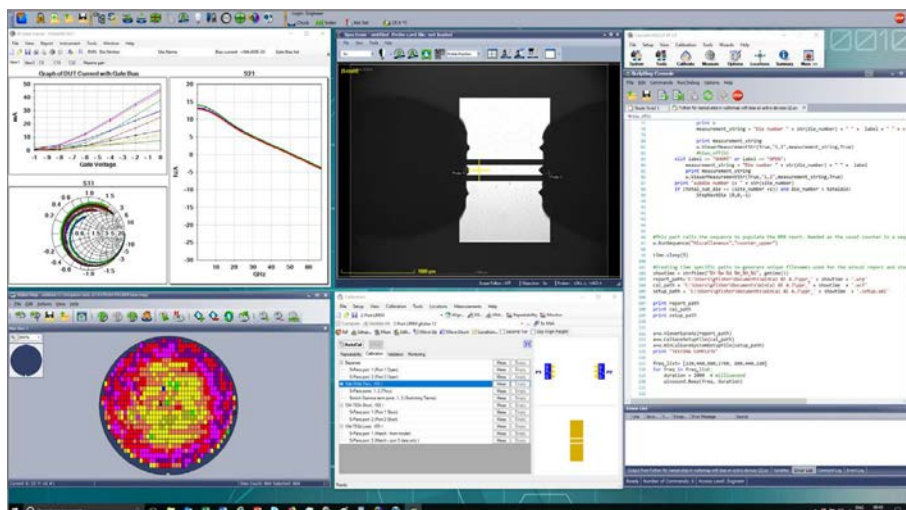

Windows screen view of WinCal and Velox

Key Features

- Patented LRRM with automatic LOAD inductance compensation function ensures the most repeatable calibrations
- Extensive guidance, wizards and management features automate calibration setup, measurement, result data conversion and report creation
- Supports precision and simple multi-port calibrations
- Easy to use Probe to ISS/CSR matching tool
- Additional remote control methods
- Interface with Velox™ over LAN
- Supports up to 12 VNA ports that can be mapped to four logical ports for calibration

Ordering Information

Part Number	Description
168-690	WinCal XE, full version (download)
168-691	WinCal XE, 30-day demo (download)
168-672	WinCal XE, field upgrade from demo to full version
168-673	WinCal XE, university version

> Supporting Accessories

Impedance Standard Substrate (ISS)

The FormFactor family of Impedance Standard Substrates (ISS) support all of your high-frequency probing applications. Using them ensures greater accuracy and better repeatability in on-wafer calibration of vector network analyzers. Only FormFactor offers the proven accuracy of LRRM calibrations with automatic load inductance compensation.

[View the ISS layouts](#)

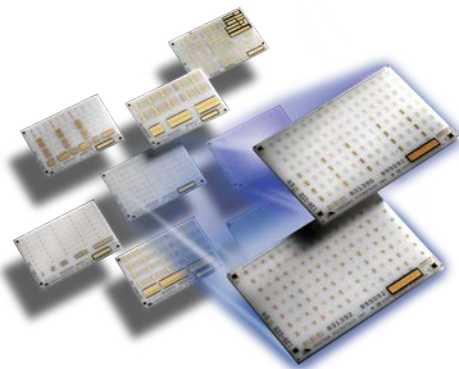

Ordering Information

GSG			
Pitch (μm)	P/N	Frequency (GHz) ¹	Note
50 to 75	162-641	325 GHz ²	Verification Lines only, no Cal structures [0.5, 1, 1.1, 1.4, 1.9, 2.3, 2.7, 3, 3.2, 3.8, 4.5, 7, 14, 27, 40] ps
50	185-400	325 GHz ²	
50 to 75	138-356	325 GHz ²	
50 to 150	104-909	67 GHz	Mix of GSG & GS/SG
75 to 150	104-783	145 GHz ²	
100 to 150	114-456	67 GHz	For probes with contact widths < 30 μm
100 to 150	138-357	325 GHz ²	
100 to 250	143-033	145 GHz ²	
100 to 250	101-190	67 GHz	
100 to 500	109-531	67 GHz	Right Angle standards; N-E, N-W, E-W
250 to 1250	106-682	67 GHz	
150 to 3000	108-010	67 GHz	Recommended > 1250 μm pitch

GS/SG			
Pitch (μm)	P/N	Frequency (GHz) ¹	Note
50 to 150	104-909	≤ 40 GHz	Mix of GSG & GS/SG
100 to 250	103-726	≤ 40 GHz	
250 to 1250	106-683	≤ 40 GHz	
150 to 3000	108-011	≤ 40 GHz	Recommended for probe pitches > 1250 μm

GSSG⁴ / THRU			
Pitch (μm)	P/N	Frequency (GHz) ¹	Note
100 to 125	129-239	67 GHz	Also supports SGS, SGSG, GSGS configurations
150	126-102	67 GHz	Also supports SGS, SGSG, GSGS configurations
150 to 225	129-240	67 GHz	Also supports SGS, SGSG, GSGS configurations
250	129-241	67 GHz	Also supports SGS, SGSG, GSGS configurations
300 to 650 ³	129-248	67 GHz	General Purpose THRU substrate (Straight, Loop Back, Cross)
700 to 1250 ³	129-249	67 GHz	General Purpose THRU substrate (Straight, Loop Back, Cross)

GSSG⁴ / THRU			
Pitch (μm)	P/N	Frequency (GHz) ¹	Note
100 to 150	129-246	67 GHz	Also supports SSG, GSS configurations
175 to 250	129-247	67 GHz	Also supports SSG, GSS configurations
300 to 950 ³	129-248	67 GHz	General Purpose THRU substrate only (Straight, Loop Back, Cross)
1000 to 1250 ³	129-249	67 GHz	General Purpose THRU substrate only (Straight, Loop Back, Cross)

Multiple Config			
Pitch (μm)	P/N	Frequency (GHz) ¹	Note
Variable	005-016	Variable	General Purpose
80 to 3000	106-686	67 GHz	General Purpose Membrane

Notes:

¹ Recommended maximum upper frequency. Usable Upper frequency will vary with pitch.

² Supports broadband coaxial probes up to 145GHz and banded Waveguide probes up to 325GHz

³ Wide Pitch: (> 250 μm) differential / multipoint calibration, additionally use the wide pitch, single-ended ISS (106-682 or 106-683)

⁴ Narrow Pitch: For dual probe with pitches <100μm, please use the matching singled-ended (GSG or GS / SG) ISS

> Supporting Accessories

Calibration Substrates (for IZI Probes)

The CSR family of calibration substrates is compatible with the IZI Probes. All CSR calibration substrates include the Open standard on the substrate itself, which can provide a more accurate calibration when compared to simply lifting the probes for Open. Also, the resistance of the Load standard remains stable within 0.3% of the ideal value (50 Ω), over a temperature range from 10 to 430 K.

[View the CSR layouts](#)

Ordering Information

Calibration Substrate Standards for IZI Probes			
P/N	Description	Pitch (μm)	CSR Map PDF
41702	CSR-4, GSG	250 to 500	CSR-4 (link)
41704	CSR-5, GS/SG	250 to 500	CSR-5
56407	CSR-6, GS/SG	50 to 250	CSR-6
62025	CSR-8, GSG	100 to 250	CSR-8
73319	CSR-9, GSG	50 to 150	CSR-9
62563	CSR-15, GSG	500 to 1250	CSR-15
69061	CSR-16, GS/SG	500 to 1250	CSR-16
71391	CSR-17, GSG	1000 to 2500	
67074	CSR-18, GS/SG	1000 to 2500	
51079	CSR-32, GSGSG	200	CSR-32
51080	CSR-33, GSGSG	250	CSR-33
51082	CSR-35, GSGSG	125	CSR-35
51876	CSR-44, GSSG	400 to 600	CSR-44
53527	CSR-50, SGS	100	CSR-50
53528	CSR-51, SGS	125 to 150	CSR-51
53529	CSR-53, SGS	200 to 250	CSR-53
53530	CSR-54, SGS	400 to 500	CSR-54
136643	Calibration substrate in a silicon wafer		

Calibration Substrates (for T-Wave Probes)

Ordering Information

Calibration Substrate Standards for T-Wave Probes		
P/N	Description	Pitch (μm)
172-885	Multi-line TRL Substrate, WR1.0, WR1.5, WR2.2, WR3.4, WR4.3, WR5.1	25
172-886	Multi-line TRL Substrate, WR2.2, WR3.4, WR4.3, WR5.1	50
172-887	Multi-line TRL Substrate, WR3.4, WR4.3, WR5.1	75 and 100

Contact Substrate

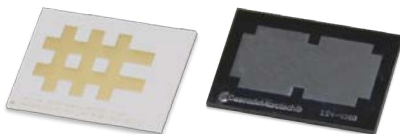

Ordering Information

Contact Substrate	
P/N	Description
005-018	Gold on ceramic. Used for planarization of probe.
154-430	Aluminum (2 μm) on silicon. Used for planarization of probes.

> Compatible System Solutions

We offer a complete line of premium performance analytical probe stations for on-wafer probing, that help increase process performance while reducing cost of ownership.

Our probe systems are available with a complete set of accessories such as microscopes, thermal control systems, software and industry-leading probes. Probe

stations are available for 300 mm, 200 mm and 150 mm, starting at \$13,880. We offer manual, semi-automated and fully-automated systems with over-temperature capability from -60 to +300°C.

Our exclusive Autonomous Measurement Assistants enable hands-free 24/7 remote probing from home.

Autonomous RF

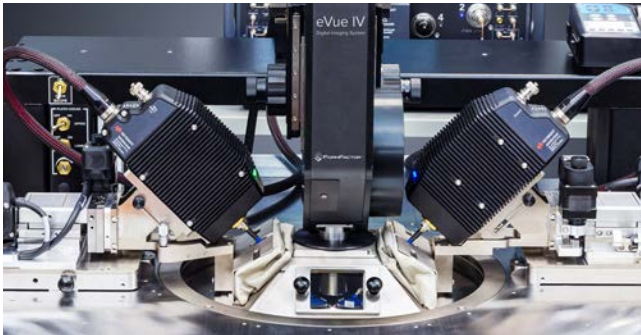

- Constantly monitors calibration accuracy and re-calibrates when needed
- Patented RF TopHat for dark, shielded and frost-free probing
- Known measurement certainty for every device measurement
- Reduced cost of test with increased accuracy
- Compatible with [InfinityXT](#), [Infinity](#), and [T-Wave](#) probes

RF / mm-Wave / Terahertz



- Lowest possible insertion loss
- Minimized drift over temperature and time
- Highest raw directivity and dynamic range
- Full thermal capability with RF TopHat
- Manual or programmable positioners
- Easy, and safe swapping between bands

mm-Wave Load-Pull

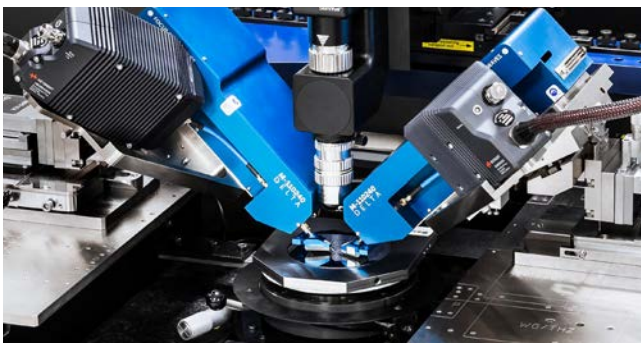

- Best-in-class tuning range: Direct connect probes maximize Gamma
- Measurements over temperature with Optional RF TopHat: -60 to 125°C EMI-shielded, dark and frost-free
- Small pad probing: High power microscope compatibility
- Calibration accuracy: Easy to perform coaxial and on-wafer calibrations

> Compatible System Solutions

Silicon Photonics

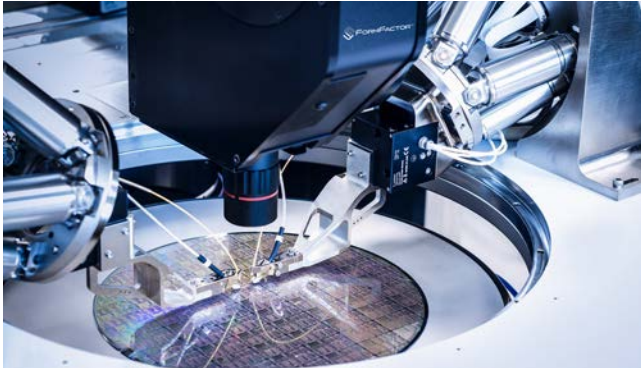

- Fully-integrated, verified solution with automated calibration and alignment
- In-situ calibrations and singulated die testing with OptoVue Pro
- Wafer and die-level edge coupling
- Automated optical positioning calibrations and Alignments
- Integrated Z-displacement
- Highly flexible solution for single fibers/arrays and edge/vertical coupling

Cryogenic Probe Stations



- Highly precise measurements of wafers and substrates in a cryogenic environment
- On-wafer and multi-chip measurements
- Wide range of challenging applications, including IR-sensor test, radiometric test, DC and RF measurements at cryogenic temperatures
- Handle wafers up to 300 mm
- Support cold filter, cold shutter and selectable f/value aperture as well as multiple optical instruments like IR radiation sources (black bodies)
- Up to eight probe positioners and/or a probe card can be integrated

>Positioners and Accessories

FormFactor offers a wide variety of manual and motorized probe positioners for any application from DC to terahertz measurements and beyond.

Engineered for high stability and accuracy, FormFactor's positioners enable precise, backlash-free and repeatable probe tip placements – from simple IV/CV measurements to highly challenging measurement tasks.

Enhanced with FormFactor's High Temperature Stability (HTS), the positioners become part of our exclusive Contact Intelligence™ Technology that enables small pad probing over a full temperature range.

Unsurpassed accuracy and highest productivity is achieved with the revolutionary Autonomous Measurement Assistants for DC, RF and Silicon Photonics testing. These wafer probing assistants utilize our programmable positioners and enable fully autonomous, hands-free measurements – minimizing training needs and accelerating time to market.

Designed and validated with proven quality standards, our positioners are always the perfect match to your FormFactor probe station.

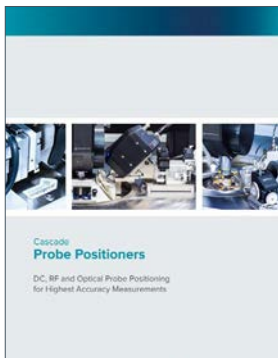

[Probe Positioners Brochure](#)



[Probe Station Accessories Catalogue](#)

➤ Accessory Waveguide Extensions

Waveguide Sections for Use with Waveguide Infinity and ACP Probes

The following Wave Guide extensions are for use with ACP, Infinity and T-Wave Wave Guide probes on FormFactor stations configured for mmW measurements. Please consult with your local sales representative to confirm your model and configuration is setup with the correct mmW accessories to be compatible with Wave Guide probes and these Wave Guide extensions.

Wave Guide S-Bend Extensions for Summit 11/12K, S300 Probing systems¹

Part Number	WR Designation	Probe Style	Nominal Frequency Band
133-999	WR15	"T"	50-75 GHz
133-998	WR12	"T"	60-90 GHz
133-997	WR10	"T"	75-110 GHz
133-996	WR8	"T"	90-140 GHz
133-995	WR6	"T"	110-170 GHz
133-994	WR5	"T"	140-220 GHz
165-695	WR4 ²	"T"	170-265 GHz
165-696	WR4	"T"	170-265 GHz
147-309	WR3 ²	"T"	220-325 GHz
151-511	WR3	"T"	220-325 GHz

¹ These WG extensions are for use with Summit 11/12k systems using Large Area Positioners and a conventional Top Hat assembly

² For use with OML type head without micrometer driven attenuator and test head, for lower loss inverted

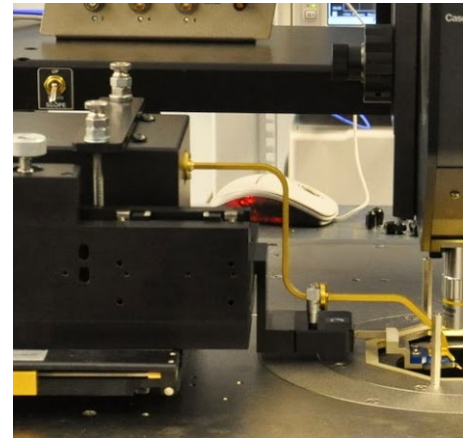

[Link to Drawings](#)

Wave Guide S-Bend Extensions for EPS150MMW, EPS150THZ, EPS200MMW, and RF150 and Summit 9/10K Probing systems

Part Number	WR Designation	Probe Style	Nominal Frequency Band
133-993	WR15	"S"	Waveguide S-bend section, WR15, EPS150MMW and EPS200MMW, 50-75 GHz
133-992	WR12	"S"	60-90 GHz
133-991	WR10	"S"	75-110 GHz
133-990	WR8	"S"	90-140 GHz
133-989	WR6	"S"	110-179 GHz
133-988	WR5	"S"	140-220 GHz
165-697	WR4 ¹	"S"	170-265 GHz
165-698	WR4	"S"	170-265 GHz
165-692	WR3	"S"	220-325 GHz
144-399	WR3 ¹	"S"	220-325 GHz
170-925	WR2 ²	1500 style	"325-500GHz, 0.5" drop and 1" long ²

¹ For use with OML type head without micrometer driven attenuator and test head, for lower loss inverted

² PN 170-925 requires chuck height adapter kit

[Link to Drawings](#)

> Accessory Waveguide Extensions

Wave Guide S-Bend Extensions for Elite 300 mmW Probing systems			
Part Number	WR Designation	Probe Style	Nominal Frequency Band
141-815	WR15	"T"	50-75 GHz
141-814	WR12	"T"	60-90 GHz
141-813	WR10	"T"	75-110 GHz
141-812	WR8	"T"	90-140 GHz
141-811	WR6	"T"	110-170 GHz
141-810	WR5	"T"	140-220 GHz
165-694	WR4	"T"	170-265 GHz
165-693	WR4 ¹	"T"	170-265 GHz ¹
147-310	WR3 ¹	"T"	220-325 GHz ¹
165-691	WR3	"T"	220-325 GHz

¹ For use with OML type head without micrometer driven attenuator and test head, for lower loss inverted

[Link to Drawings](#)

Wave Guide 45° bend Extensions for TopHat mmW versions of SUMMIT200, CM300, Elite 300 and Summit 12k Probing systems			
Part Number	WR Designation	Probe Style	Nominal Frequency Band
184-410	WR15	"S"	50-75 GHz, RF TopHat
184-411	WR12	"S"	60-90 GHz, RF TopHat
184-412	WR10	"S"	75-110 GHz, RF TopHat
184-413	WR8	"S"	90-140 GHz, RF TopHat
184-414	WR6	"S"	110-170 GHz, RF TopHat
184-415	WR5	"S"	140-220 GHz, RF TopHat
184-416	WR4	"S"	170-260 GHz, RF TopHat
184-417	WR3	"S"	220-330 GHz, RF TopHat
185-640	WR2	"S"	325-500 GHz, RF TopHat

[Link to Drawings](#)

Wave Guide 45° bend Extensions for Non-TopHat mmW versions of SUMMIT200, CM300, Elite 300, Summit 12k, EPS200MMW, EPS150MMW and EPS150THZ Probing systems			
Part Number	WR Designation	Probe Style	Nominal Frequency Band
184-419	WR15	"S"	50-75 GHz, Non-TopHat
184-420	WR12	"S"	60-90 GHz, Non-TopHat
184-421	WR10	"S"	75-110 GHz, Non-TopHat
184-422	WR8	"S"	90-140 GHz, Non-TopHat
184-423	WR6	"S"	110-170 GHz, Non-TopHat
184-424	WR5	"S"	140-220 GHz, Non-TopHat
184-425	WR4	"S"	170-260 GHz, Non-TopHat
184-426	WR3	"S"	220-330 GHz, Non-TopHat
185-639	WR2	"S"	325-500 GHz, Non-TopHat

[Link to Drawings](#)

Supporting Accessories

Cables

FormFactor offers a wide variety of low-loss, higher-quality measurements and repeatable calibration results. Each cable has a male connector at one end that connects to the probe and a female connector at the other end to connect to the test instrumentation. For vertical style probes, the male connector includes an integrated 90° elbow.

Freq (GHz)	Probe station	Body Style	Length	Part Number
DC to 40	CM300xi, Elite300, SUMMIT200, Summit 11/12K	A	48 inch	180-802 ³
		V	48 inch	180-803 ³
	EPS with SMZ168, no MicroChamber	A	48 inch	180-800
	EPS with SlimVue, no MicroChamber	V	48 inch	180-801
DC to 50	CM300xi, Elite300, SUMMIT200, Summit 11/12K	A	48 inch	180-806 ³
		V	48 inch	180-807 ³
	EPS with SMZ168, no MicroChamber	A	48 inch	180-804
	EPS with SlimVue, no MicroChamber	V	48 inch	180-805
DC to 67	CM300xi, Elite300, SUMMIT200, Summit 11/12K	A	36 inch	180-810 ³
		V	36 inch	180-811 ³
	EPS with SMZ168, no MicroChamber	A	36 inch	180-808
	EPS with SlimVue, no MicroChamber	V	36 inch	180-809
DC to 110	CM300xi, Elite300, SUMMIT200, Summit 11/12K ¹	A	24 cm	180-813 ³
	EPS150/200 with SlimVue, Summit 11/12K ¹	A	18 cm	180-812
	CM300xi ¹ , Elite300 ¹ , SUMMIT200 ¹ , EPS with SlimVue ¹	A	10 cm	178-383 ³
	CM300xi ² , Elite300 ² , SUMMIT200 ² , EPS150/200 with SlimVue ²	A	13 cm	178-387 ³

For applications above 50 GHz, a rear-mounted instrument rack is recommended.

¹ For single port

² For multiport

³ Cables for shielded environments with TopHat

A = 45° angled coaxial connector body style

V = vertical coaxial connector body style



Angled probe body style

Vertical probe body style

Probe Cleaning Accessories

P/N	Description
134-208	Probe needle cleaning pads, .5 x .75 inches, "probe clean", pkg of 5
134-209	Probe needle cleaning pads, .5 x .75 inches, "probe polish", pkg of 5
134-210	Probe needle cleaning pads, .5 x .75 inches, "probe scrub", pkg of 5
113-477	Probe cleaning brush
174-090	Tungsten Carbide Cleaning Substrate
174-091	Tungsten Carbide Clean Contact Verification Substrate

> Drawing Appendix

Infinity Probes

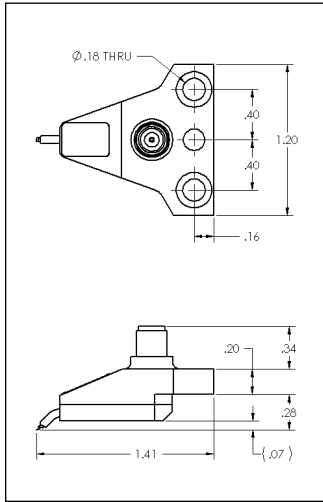

Infinity Probe, vertical body style

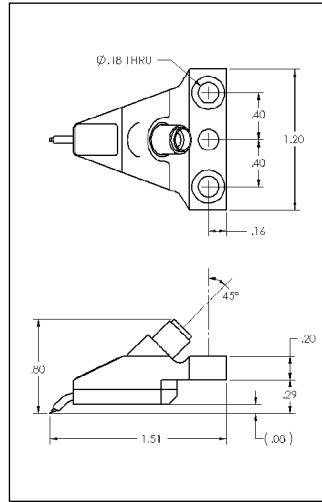

Infinity Probe, angled body style

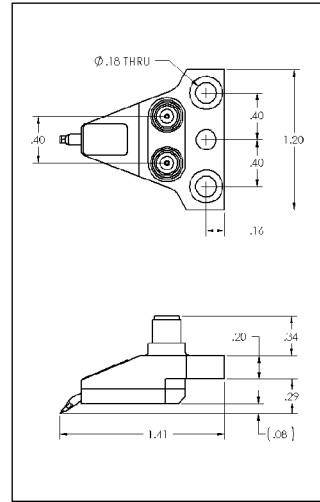

Dual Infinity Probe, vertical body style

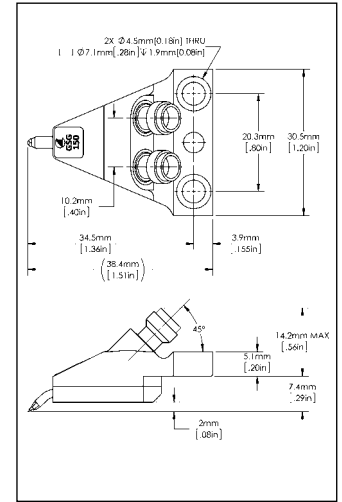

Dual Infinity Probe, angled body style

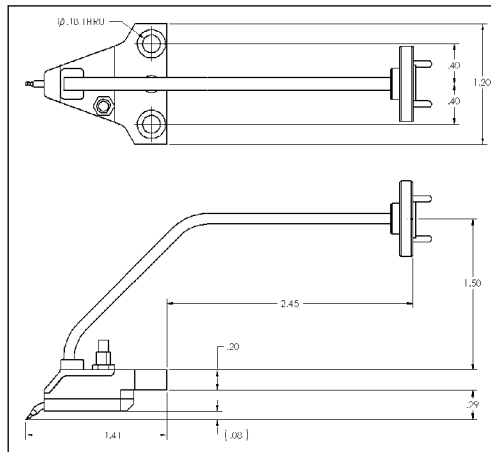
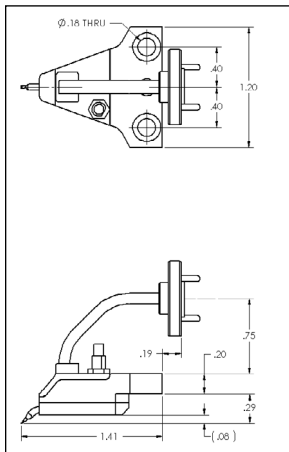

Waveguide Infinity Probe - "S" Model on the left, and "T" Model on the right

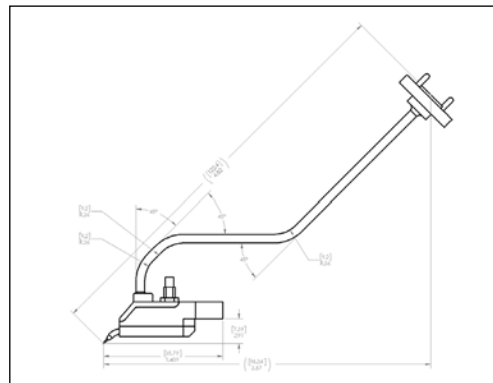
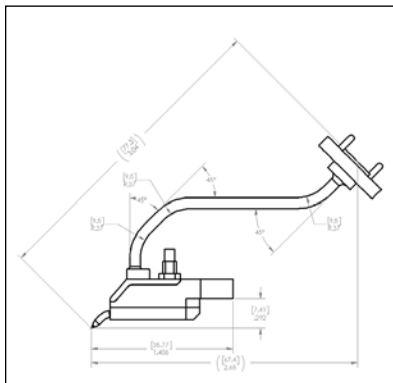

Waveguide Infinity Probe - "SA" Model on the left, and "TA" Model on the right

> Drawing Appendix

Air Coplanar Probes

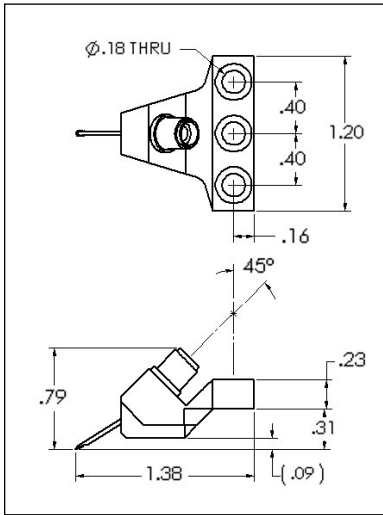

Probe style for: ACP40-Ax, ACP50-Ax, ACP65-Ax, ACP110-Ax.

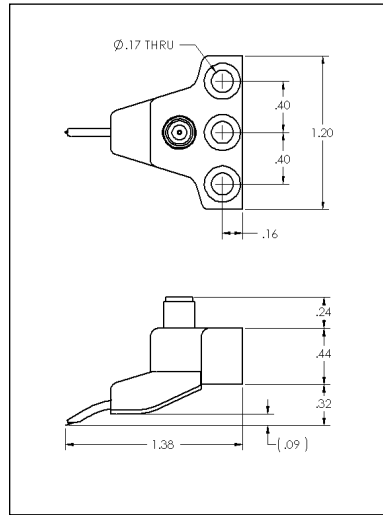

Probe style for: ACP40-x, ACP50-x, ACP65-x, ACP110-Cx.

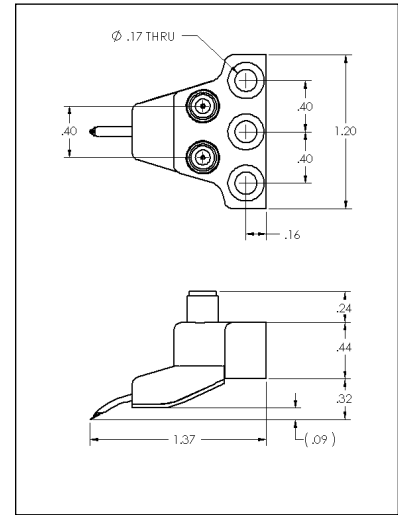

Probe style for: ACP40-Dx, ACP50-Dx, ACP65-Dx, ACP110-Dx.

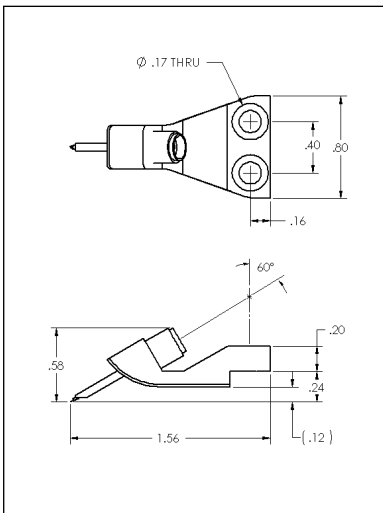

Probe style for: ACP40-Lx, ACP50-Lx, ACP65-Lx, ACP110-Lx.

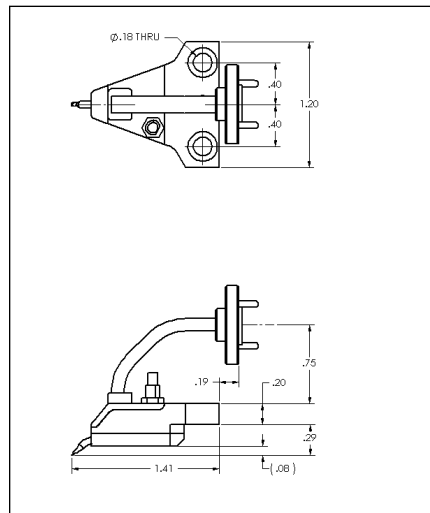

Waveguide ACP Probe - "S" Model

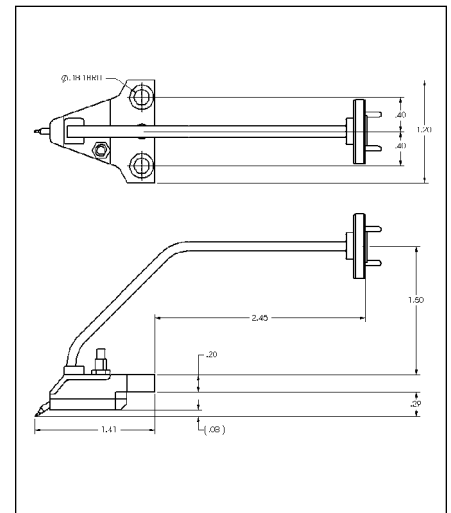

Waveguide ACP Probe - "T" Model

> Drawing Appendix

T-Wave Probes

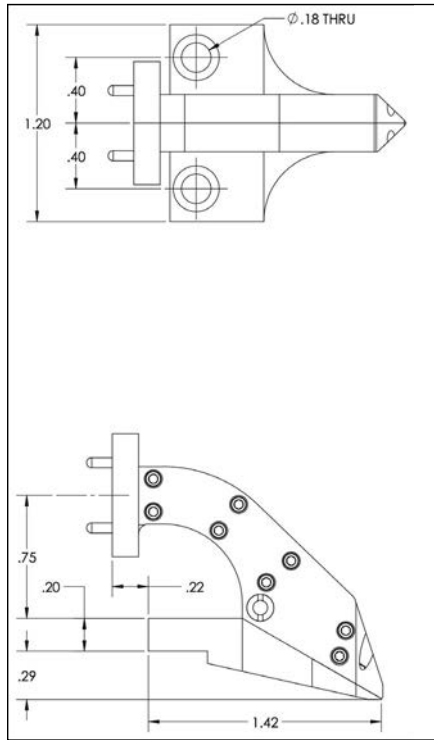

T-Wave Probe – "S" Model

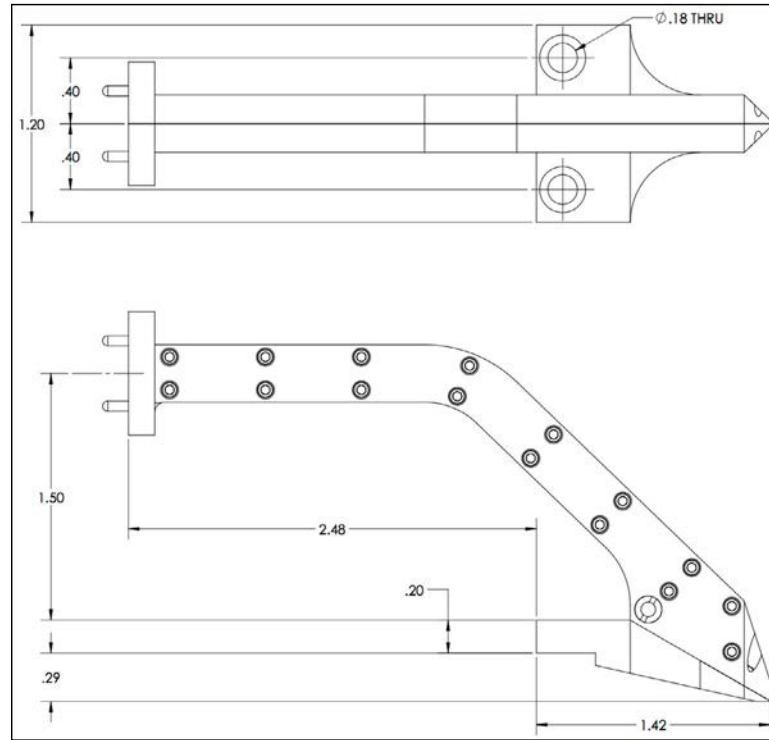

T-Wave Probe – "T" Model

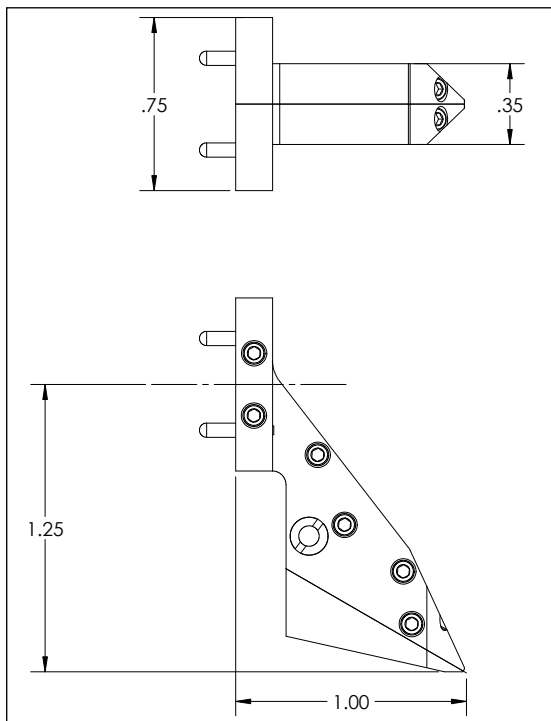

T-Wave Probe – 1.1 THz Model,
T-Wave Probe – 750 GHz Model

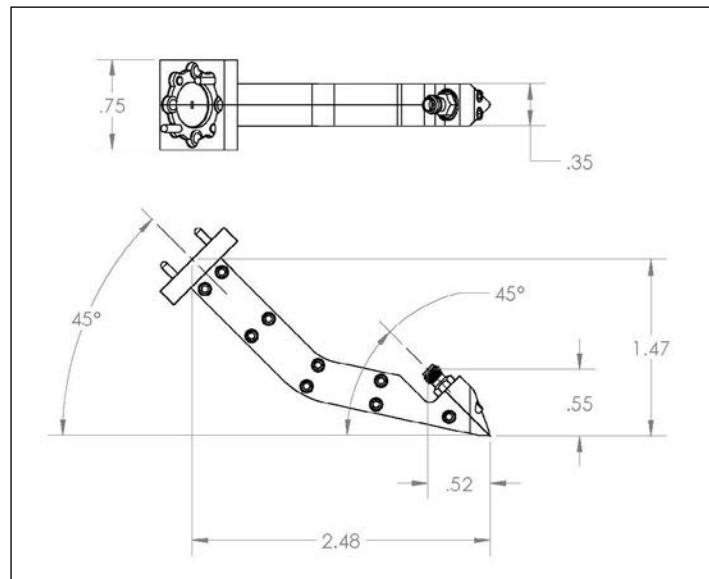

T-Wave Broadband Probe
Models: T170-UBBT-GSG-xxx / T220-UBBT-GSG-xxx

> Drawing Appendix

IZI Probes

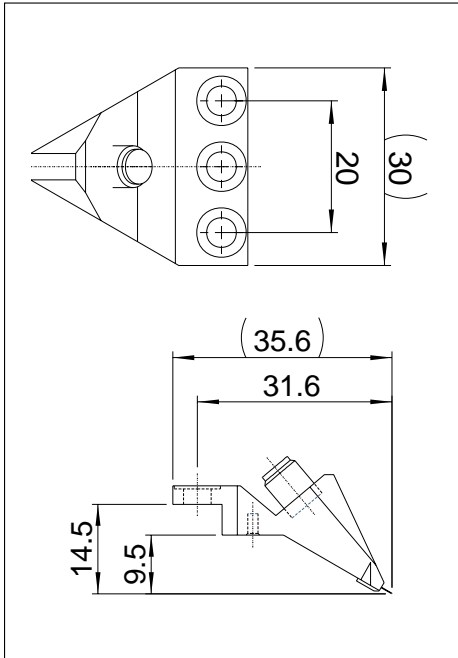

Probe style for IZI Probes (mm)

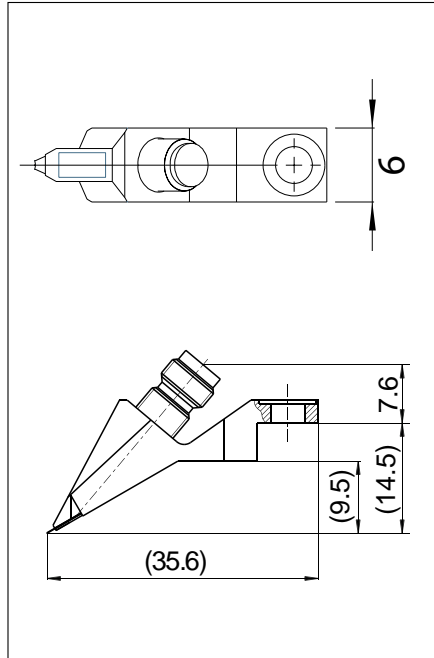

Probe style for Slim IZI Probes (mm)

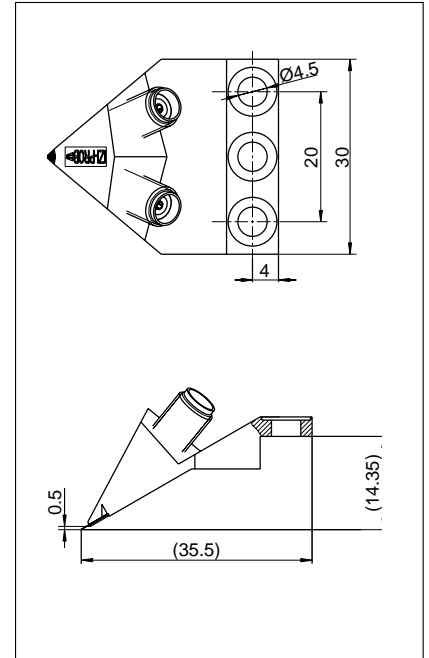

Probe style for Dual IZI Probes (mm)

Mixed Signal Multi-IZI Probe

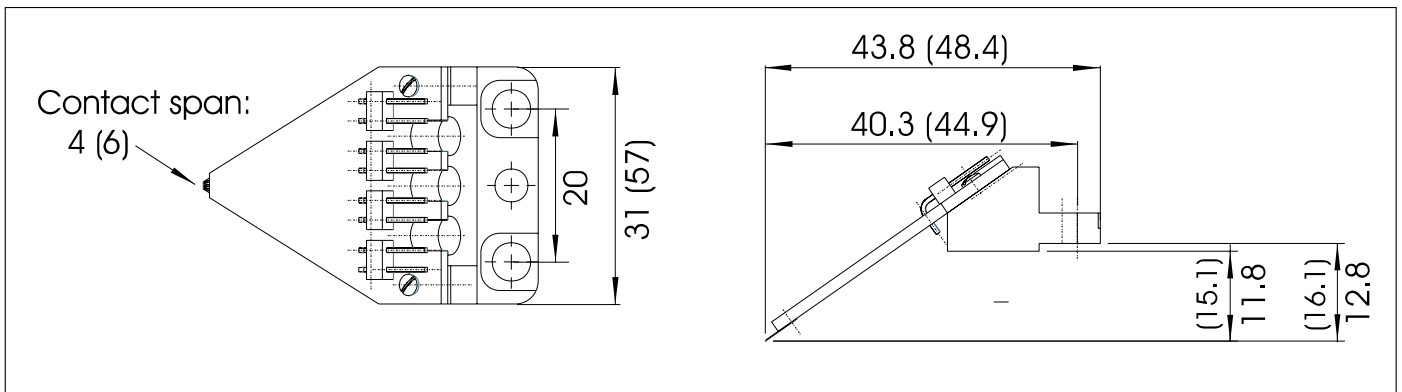

Multi-IZI Probe 3 to 7 pins with medium board size (mm).
Variational figures for Multi-IZI Probe 7 to 25 pins with large board size in brackets.

> Drawing Appendix

Multi-contact Probes

RF (Mixed Signal) Multi-contact Probes

InfinityQuad Probe

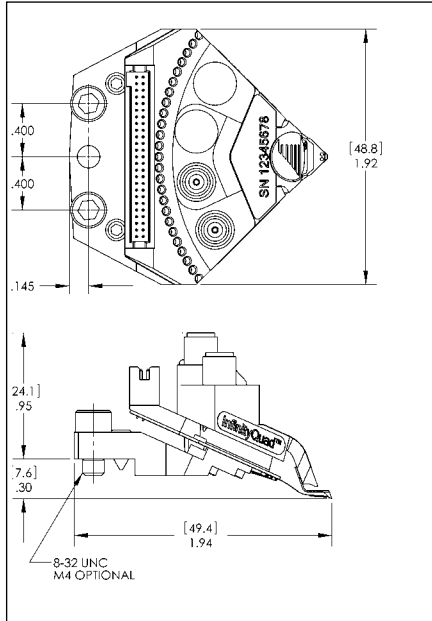

Unity Probe

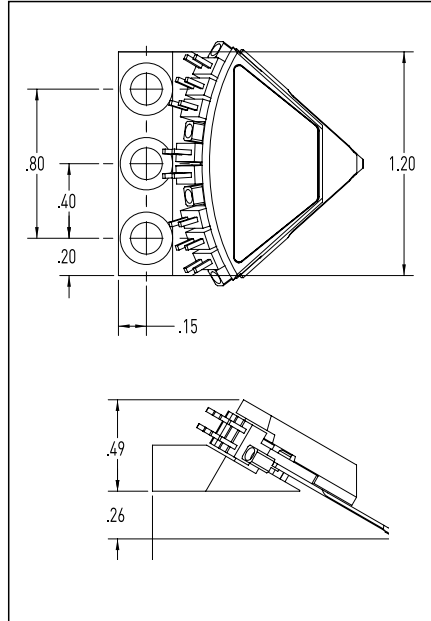

ACP Quadrant Probe

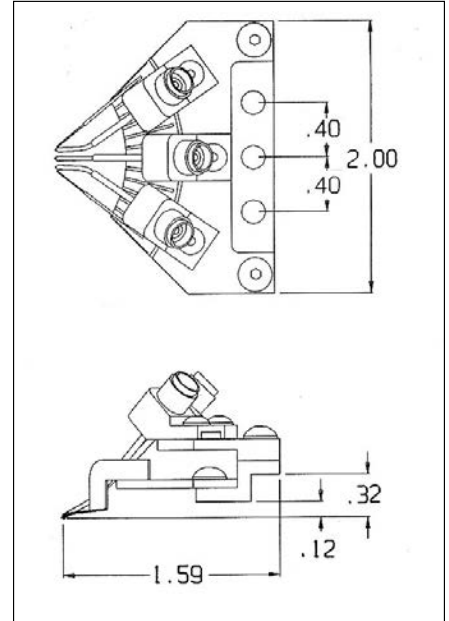

DC Multi-contact Probes

DCQ Quadrant Probe

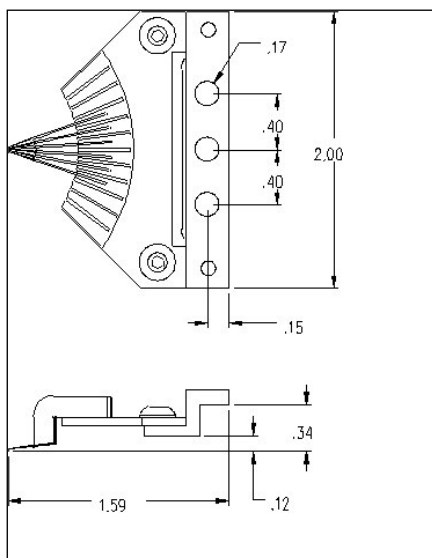

WPH Quadrant Probe

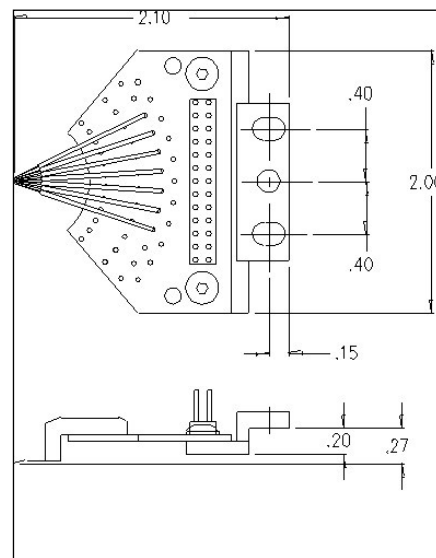

Eye-Pass Probe

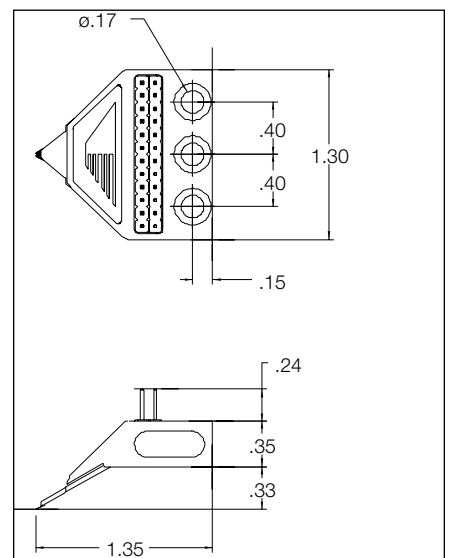

> Drawing Appendix

Board Test and Signal Integrity Probes

Fixed-Pitch Compliant Probe (FPC)

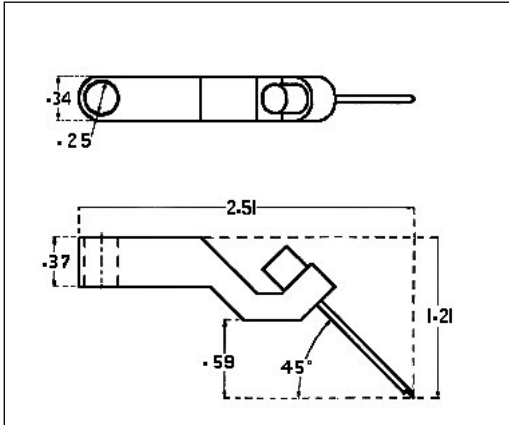

IZI Probe PCB

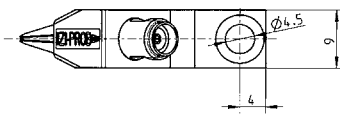

Slim version (single hole mount)

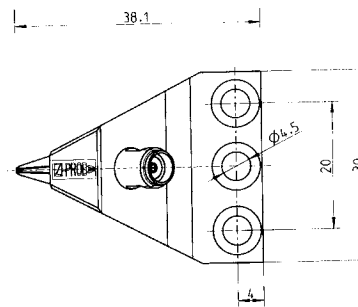
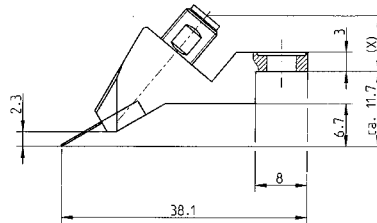

Three hole mount version

> Drawing Appendix

Waveguide Extensions

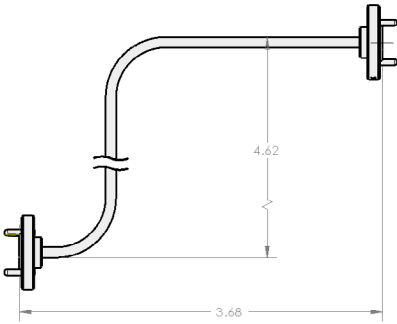

Example for Elite 300 Systems

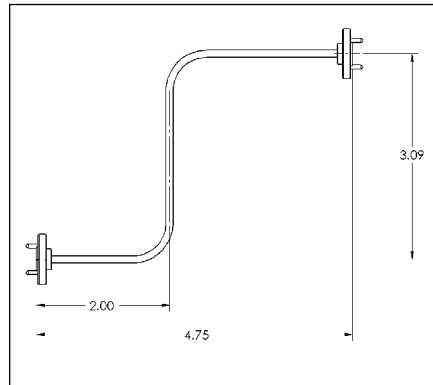

Wave Guide S-Bend Extensions for
EPS150MMW, EPS150THZ, EPS200MMW, and
RF150 and Summit 9/10K Probing systems

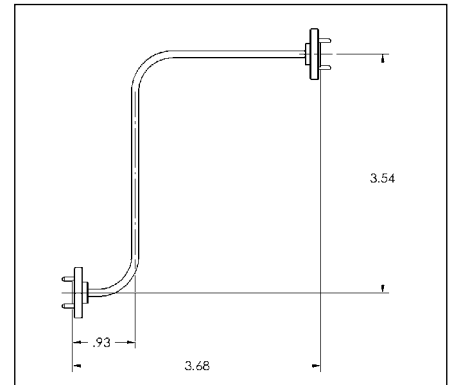

Wave Guide S-Bend Extensions for Summit
11/12K, S300 Probing systems

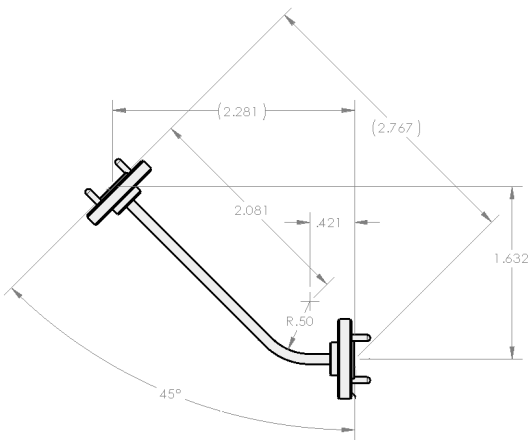

Example for SUMMIT200 & CM300 with 45
degree setup with TopHat

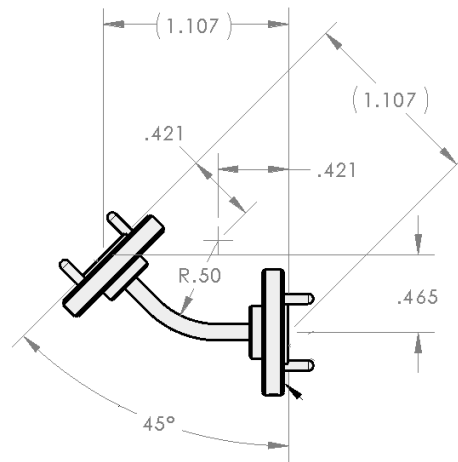

Example for SUMMIT200 & CM300 with 45 degree setup
without TopHat

©Copyright 2023. FormFactor, Inc. All rights reserved. FormFactor and the FormFactor logo are trademarks of FormFactor, Inc. All other trademarks are the property of their respective owners.

All information is subject to change without notice.

ProbeSelectionGuide-0523

Corporate Headquarters

7005 Southfront Road

Livermore, CA 94551

Phone: 925-290-4000

www.formfactor.com

