

# CM300xi Probe System

This guide defines the facility requirements for operation of your FormFactor CM300xi or CM300 probe station. Facility requirements for thermal systems are listed separately. See the Facility Planning Guide specific to your thermal system for details. For information specific to the CM300xi-ULN station, see the *CM300xi-ULN Facility Planning Guide*. For definitions of the icons in this document, please refer to the notational conventions described in your user guide.

## Probe Station Requirements

<b>Clean Dry Air (CDA)</b>	<p>CDA requirements vary depending on the system configuration and the temperature range in which the system will operate. CDA for <a href="#">General use</a> purposes is always required, and is used for basic system functions like base table damping. CDA for the <a href="#">MicroChamber probing environment (PURGE)</a> is additionally required for shielded and fully-shielded probe stations, such as CM300xi-S, CM300xi-F and CM300xi-ULN. CDA requirements for the thermal system (if applicable) are listed separately.</p>
General use (CDA VIT)	<ul style="list-style-type: none"> <li>• ISO 8573.1 Class 1.4.1 (3°C pressure dew point, oil less than 0.01 mg/m3)</li> <li>• 8 mm OD push-in tube connection</li> <li>• 6-10 bar (87-145 psi)</li> <li>• CM300xi-S, -F, -ULN:                         <ul style="list-style-type: none"> <li>– Flow rate for semi-automated prober: max. 10 l/min</li> <li>– Flow rate for fully-automated single prober with MHU301/MHU300 (1 loadport): max. 40 l/min</li> <li>– Flow rate for fully-automated dual prober system with MHU300 and 2 loadports: max. 80 l/min</li> </ul> </li> <li>• CM300-O:                         <ul style="list-style-type: none"> <li>– Flow rate for semi-automated prober: max. 30 l/min</li> <li>– Flow rate for fully-automated single prober with MHU301/MHU300 and 1 loadport: max. 70 l/min</li> <li>– Flow rate for fully-automated dual prober system with MHU300 and 2 loadports: max. 110 l/min</li> </ul> </li> </ul>
MicroChamber probing environment (PURGE) (for shielded and fully-shielded system configurations only. Not applicable for CM300-O.)	<ul style="list-style-type: none"> <li>• ISO 8573.1 Class 1.x.1 (required pressure dew point is dependent on operating temperature, oil less than 0.01 mg/m3), 7-10 bar (102-145 psi)                         <ul style="list-style-type: none"> <li>– Required pressure dew point of PURGE air is dependent on operating temperature range:                                 <ul style="list-style-type: none"> <li>○ Thermal system operated down to +20°C: ≤-20°C at SATP* -&gt; ISO8573.1 class 1.3.1</li> <li>○ Thermal system operated down to -40°C: ≤-50°C at SATP* -&gt; ISO8573.1 class 1.1.1</li> <li>○ Thermal system operated down to -60°C: ≤-70°C at SATP* -&gt; ISO8573.1 class 1.1.1</li> </ul> </li> </ul> </li> <li>• Semi- and fully-automated systems (one station):                         <ul style="list-style-type: none"> <li>– Max flow: 240 l/min (8.5 CFM) at SATP*</li> <li>– Continuous flow: 80 l/min (2.8 CFM) at SATP*</li> </ul> </li> <li>• Dual-prober systems (two stations):                         <ul style="list-style-type: none"> <li>– Max flow: 480 l/min (17 CFM) at SATP*</li> <li>– Continuous flow: 160 l/min (5.6 CFM) at SATP*</li> </ul> </li> </ul> <p><b>NOTE   HINWEIS   REMARQUE</b></p> <p><i>Lower available peak flow may extend cooling and conditioning times.</i></p> <p><i>Ein niedrigerer verfügbarer Spitzenfluss kann die Kühl- und Konditionierungszeiten verlängern.</i></p> <p><i>Un débit de pointe plus faible peut prolonger les temps de refroidissement et de conditionnement.</i></p> <ul style="list-style-type: none"> <li>• 12 mm OD push-in tube connection (3 m max tube length)</li> </ul>

# CM300xi Probe System

CDA (cont'd)	MicroChamber probing environment (purge) (cont'd)	 <p><b>DANGER   ACHTUNG   DANGER</b></p> <p>FormFactor does not endorse or recommend using nitrogen instead of CDA for thermal system operation with any FormFactor system due to the risk of oxygen depletion in the working environment. If your testing configuration requires the use of nitrogen instead of CDA for MicroChamber purge, time in Quick Purge mode should be controlled. Discuss your setup with your safety and facilities departments to ensure that the oxygen flow in your working environment is adequate to dissipate any nitrogen build up. The use of oxygen sensor alarms is also recommended.</p> <p>FormFactor schreibt die Verwendung von Stickstoff anstelle von reiner Trockenluft nicht vor und spricht hierfür auch keine Empfehlung aus, was die verschiedenen FormFactor-Systeme anbetrifft. Es besteht nämlich das Risiko, dass am Einsatzort der Luftsauerstoff aufgebraucht wird. Wenn Sie sich für die Verwendung von Stickstoff entscheiden, da Ihre Testkonfiguration für die MicroChamber-Spülung die Verwendung von Stickstoff anstelle von reiner Trockenluft erfordert, ist eine Begrenzung der Zeit, in der das System im Schnellspülmodus (Quick Purge) verweilt, erforderlich, da fortlaufend Stickstoff aus dem System an die Umwelt abgegeben wird. Sprechen Sie Ihren Systemaufbau mit Ihren Beauftragten für Arbeitssicherheit und Anlagenmanagement durch um sicherzustellen, dass ausreichend Sauerstoff in der Raumluft Ihrer Arbeitsumgebung vorhanden ist und eine übermäßige Anreicherung der Raumluft mit Stickstoff verhindert werden kann. Darüber hinaus wird die Verwendung eines Alarmsystems mit Sauerstoffsensoren empfohlen.</p> <p>FormFactor n'approuve ni ne recommande l'utilisation d'azote au lieu d'air sec propre sur aucun de ses systèmes, en raison du risque d'appauvrissement en oxygène que cela peut entraîner en milieu de travail. Si vous décidez d'utiliser de l'azote car votre configuration de contrôle nécessite son emploi au lieu d'air sec propre pour purger le système MicroChamber, vous devez limiter le temps consacré en mode de purge rapide (Quick Purge), car l'azote sera constamment évacué du système vers l'environnement. Discutez de votre configuration avec les services responsables de la sécurité et des installations pour vous assurer que le débit d'oxygène dans l'environnement de travail est suffisamment adéquat pour éviter une accumulation excessive d'azote. L'utilisation d'un détecteur d'oxygène est également recommandée.</p>
Vacuum	<ul style="list-style-type: none"> <li>• Wafer hold on chuck and positioners: <ul style="list-style-type: none"> <li>– Required: &lt; 250 mbar (7.4 inHg) absolute/ &lt; -760 mbar (-22.5 inHg) gauge at SATP*. Absolute vacuum pressure must not increase for leakage rates up to 10 l/min (0.35 CFM).</li> <li>– 10 mm OD push-in tube connection (3 m max tube length)</li> </ul> </li> <li>• Wafer hold only (while under test to ensure measurement performance): <ul style="list-style-type: none"> <li>– Vacuum pressure stability: ± 10 mbar (0.3 inHg)</li> </ul> </li> </ul>	
Power	Dual-prober probe station	<p>With MHU300</p> <p>(Includes 2 semi-automated stations, wafer handler, 1 thermal system, second thermal system is independently powered and integrated in the prober EMO)</p> <ul style="list-style-type: none"> <li>• 3 phase: 120/208 VAC 60 Hz, 230/400 VAC 50 Hz, or 200 VAC 50/60 Hz</li> <li>• Maximum: 8100 VA</li> <li>• Short circuit current rating: 10 kA (UL508A)</li> <li>• Source: <ul style="list-style-type: none"> <li>– North America: NEMA L21-30P 30A/208V/3~ grounded mains plug</li> <li>– Europe: IEC 60309 32A/400V/3~ grounded mains plug</li> <li>– Asia: IEC 60309 32A/400V/3~ grounded mains plug</li> <li>– Japan: NEMA L15-30P 30A/250V/3~, 4 wire grounding</li> </ul> </li> </ul>

# CM300xi Probe System

Power (cont'd)	Fully-automated probe station	With MHU300	<p>(Max. configuration includes 1 semi-automated station, wafer handler, 2 load ports, 1 thermal system)</p> <ul style="list-style-type: none"> <li>• 3 phase: 120/208 VAC 60 Hz, 230/400 VAC 50 Hz, or 200 VAC 50/60 Hz</li> <li>• Maximum: 8100 VA</li> <li>• Short circuit current rating (SCCR): 10 kA (UL508A)</li> <li>• Main connector: <ul style="list-style-type: none"> <li>– North America: NEMA L21-30P 30A/208V/3~ grounded mains plug</li> <li>– Europe: IEC 60309 32A/400V/3~ grounded mains plug</li> <li>– Asia: IEC 60309 32A/400V/3~ grounded mains plug</li> <li>– Japan: NEMA L15-30P 30A/250V/3~, 4 wire grounding</li> </ul> </li> <li>• Facility power line fuse: <ul style="list-style-type: none"> <li>– 3 x 32A IEC60269 class gG or 3 x 30A UL248 class J (lead fuses)</li> <li>– System input contains a 3x 30 A fuse according to UL 489</li> </ul> </li> </ul>
	Fully-automated probe station	With MHU301 (MHU only)	<ul style="list-style-type: none"> <li>• Dual-prober systems (two stations): <ul style="list-style-type: none"> <li>– Max flow: 480 l/min (17 CFM) at SATP*</li> <li>– Continuous flow: 160 l/min (5.6 CFM) at SATP*</li> </ul> </li> </ul> <p><b>NOTE   HINWEIS   REMARQUE</b></p> <p><i>These specifications apply only to the MHU301. For complete system requirements, add the power specifications shown for <a href="#">Semi-automated probe station</a> to the specifications listed here.</i></p> <p><i>Diese Spezifikationen gelten nur für die MHU301. Zur Vervollständigung der Systemanforderungen fügen Sie die für die halbautomatische Prüfstation ausgewiesenen Leistungsdaten zu den hier aufgeführten Spezifikationen hinzu.</i></p> <p><i>Ces spécifications s'appliquent uniquement à la station MHU301. Pour une configuration complète du système, ajoutez les spécifications d'alimentation indiquées pour la station de sonde semi-automatique aux spécifications répertoriées ici.</i></p> <ul style="list-style-type: none"> <li>• Single phase: 100-240VAC ±10%, 50/60 Hz</li> <li>• Maximum 1500 VA</li> <li>• Short circuit current rating (SCCR): 5 kA (UL508A)</li> <li>• Main connector: <ul style="list-style-type: none"> <li>– Grounded IEC appliance inlet C14, according to IEC 60320, UL 498, CSA C22.2 no. 42 (for cold conditions) pin-temperature 70°C, 10 A, protection class I.</li> <li>– A region dependent power cord connects IEC C14 to common local power plug (1 phase, grounded).</li> </ul> </li> <li>• Facility power line fuse: 1x 16A IEC60269 class gG or 1x 15A UL248 class J (lead fuses)</li> <li>• Protection class: I (IEC 61140)</li> </ul>
	Semi-automated probe station	(Includes station, controller, monitors, microscope)	<ul style="list-style-type: none"> <li>• Single phase: 100-127 VAC or 208-240 VAC 50/60 Hz</li> <li>• Maximum 1500 VA</li> <li>• Short circuit current rating (SCCR): 5 kA (UL508A)</li> <li>• Main connector: Grounded IEC appliance inlet C14, according to IEC 60320, UL 498, CSA C22.2 no. 42 (for cold conditions) pin-temperature 70°C, 10 A, protection class I. A region dependent power cord connects IEC C14 to common local power plug (1 phase, grounded).</li> <li>• Facility power line fuse: semi-automated 1x 16A IEC60269 class gG or 1x 15A UL248 class J (lead fuses)</li> </ul>
	Circuit breaker		<ul style="list-style-type: none"> <li>• Minimum rating: 10,000 AIC</li> </ul>
	Overvoltage		<ul style="list-style-type: none"> <li>• Transient overvoltage: Category II (IEC 60364-4-443)</li> <li>• Main supply voltage fluctuations not to exceed ± 10% of the nominal voltage</li> </ul>

# CM300xi Probe System

<b>Power (cont'd)</b>	AC power line harmonics	<ul style="list-style-type: none"> <li>Fundamental power line frequency to 50<sup>th</sup> harmonic</li> <li>Total harmonics &lt;3%</li> </ul>	
	For information on other optional components, refer to the data sheet for the particular item.		
<b>Thermal systems</b>	Refer to the facility preparation guide for your thermal system.		
<b>Environmental conditions</b>	Operating	<ul style="list-style-type: none"> <li>Indoors only</li> <li>Altitude up to 2000 m</li> </ul>	
	Temperature	<ul style="list-style-type: none"> <li>Operating range: +18°C to +24°C</li> <li>Max. temperature variation: +/- 1 K</li> </ul>	
	Relative humidity	• 20% to 60% (20% to 50% with sub-ambient thermal system)	
	IP rating	• X0	
	Pollution degree	• 2	
	Ambient vibration (including floor)	<p>The probe station is intended for use in an environment having background vibrations at or below the ISO operating theatre level:</p> <ul style="list-style-type: none"> <li>Maximum level 4000 micro-in./sec, measured using the 1/3-octave-band velocity spectra method. This is equivalent to 100 µm/s of displacement velocity, or 100 µg (g = 9.8 m/s<sup>2</sup>), and equivalent to a displacement acceleration of 100 µm/ s<sup>2</sup>.</li> </ul>	
	Clean room class	• Class ISO 7 corresponding to ISO 14644-1 (equivalent class 10,000 per US FED STD209E)	
<b>Dimensions (WxDxH)</b>	Probe station(s)	See <a href="#">Dimensions</a> on page 5 for details on dual prober, fully- and semi-automated system configurations.	
	Joystick	<ul style="list-style-type: none"> <li>102 x 150 x 150 mm (4 x 6 x 6 in.), with connector installed</li> <li>Located on the control console. Alternate placement may require an additional table.</li> </ul>	
	Clearance	Front	• 800 mm (32 in.) for operator/installation during installation or service
		Back	<ul style="list-style-type: none"> <li>1000 mm (39 in.) for service access</li> <li>800 mm (32 in.) when using optional holders for monitor, keyboard or test instrument</li> </ul>
		Left/right	<ul style="list-style-type: none"> <li>200 mm (8 in.) for cables, maximum 450 mm (18 in.) for use of control console</li> <li>800 mm (32 in.) during installation or service, or permanently when using optional holders for monitor, keyboard or test instrument</li> </ul>
		Top	• 400 mm (16 in.)
Additional clearance may be required for thermal system cooling units.			
<b>Weight</b>	Probe station	Dual-prober	• Max. 2800 kg (6170 pounds)
		Fully-automated	<ul style="list-style-type: none"> <li>With MHU300 = max. 1650 kg (3640 pounds)</li> <li>With MHU301 = max. 1300 kg (2870 pounds)</li> </ul>
		Semi-automated	• Max. 1150 kg (2540 pounds)
	Actual weight depends on configuration. A forklift is required for moving/unpacking the station(s) and MHU300.		
<b>Shipping dimensions (WxDxH)</b>	Probe station crate(s)	• 1430 x 1930 x 2050 mm (56 x 76 x 81 in.)	
	Loader crate	<ul style="list-style-type: none"> <li>MHU300 = 1400 x 1950 x 1850 mm (55 x 77 x 73 in.)</li> <li>MHU301 = 740 x 1180 x 1590 mm (29 x 46 x 63 in.)</li> </ul>	
	Accessories, up to 5 boxes	• Max. size: 1400 x 1500 x 1600 mm (55 x 59 x 63 in.)	
<b>Shipping weight</b>	Station crate(s)	• ≈1350 kg (2980 pounds)	
	Loader crate	<ul style="list-style-type: none"> <li>MHU300 = ~500 kg (1100 pounds)</li> <li>MHU301 ≈ 200 kg (440 lb)</li> </ul>	
	Accessories, up to 5 boxes	• Maximum weight depends on system configuration	

\* Standard Ambient Temperature And Pressure (SATP)

# CM300xi Probe System

## Dimensions



### NOTE

Maximum height is shown. Actual height is determined by light tower type. Microscope transport type varies depending on system configuration.

Die maximale Höhe wird angezeigt. Die tatsächliche Höhe hängt vom Typ des Lichtmasts ab. Der Transporttyp des Mikroskops variiert je nach Systemkonfiguration.

L'illustration montre la hauteur maximale. La hauteur réelle est déterminée par le type de tour d'éclairage. Le type de transport du microscope varie en fonction de la configuration du système.

### Semi-automated Probe Station without MHU

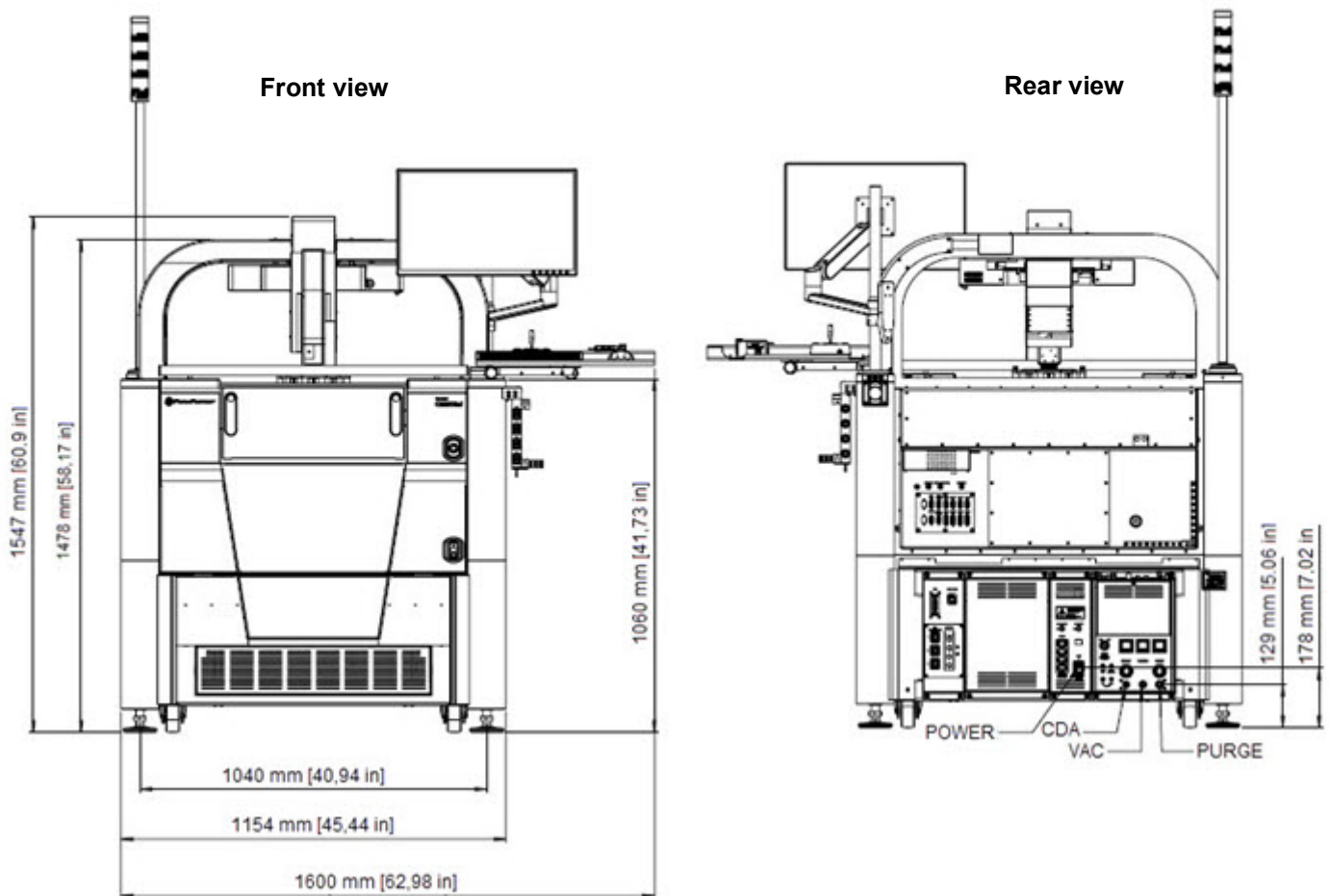

# CM300xi Probe System

Top view

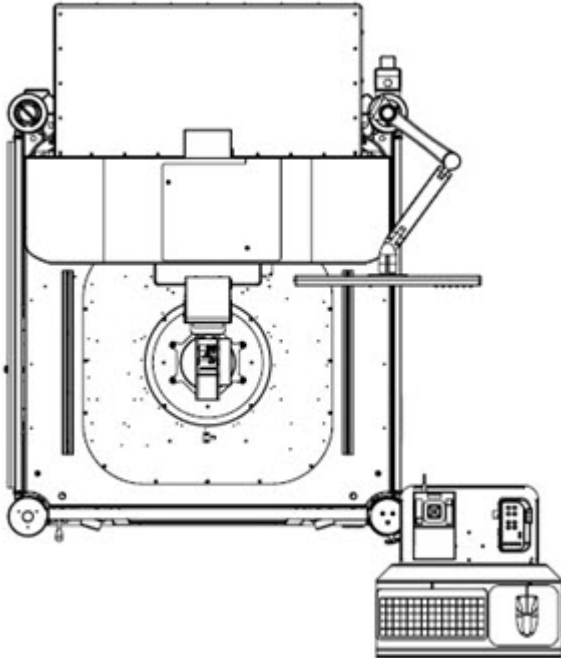

Bottom view

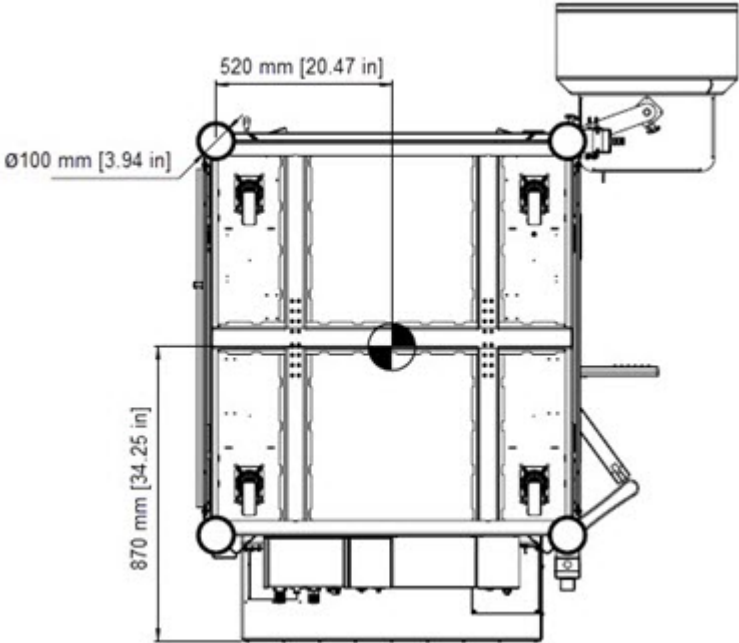

Side views

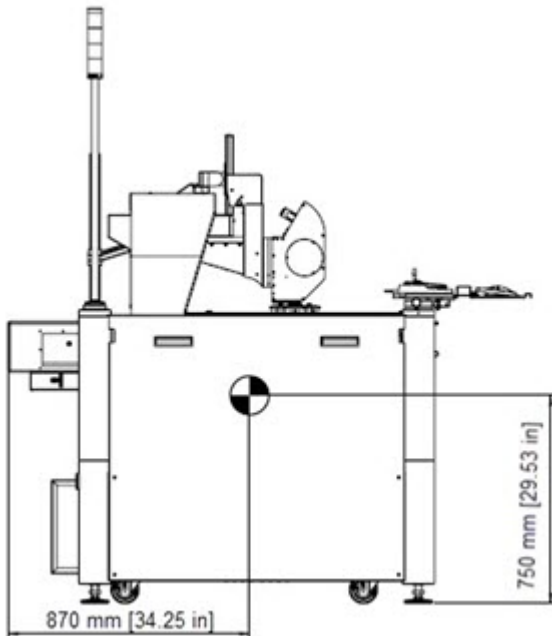
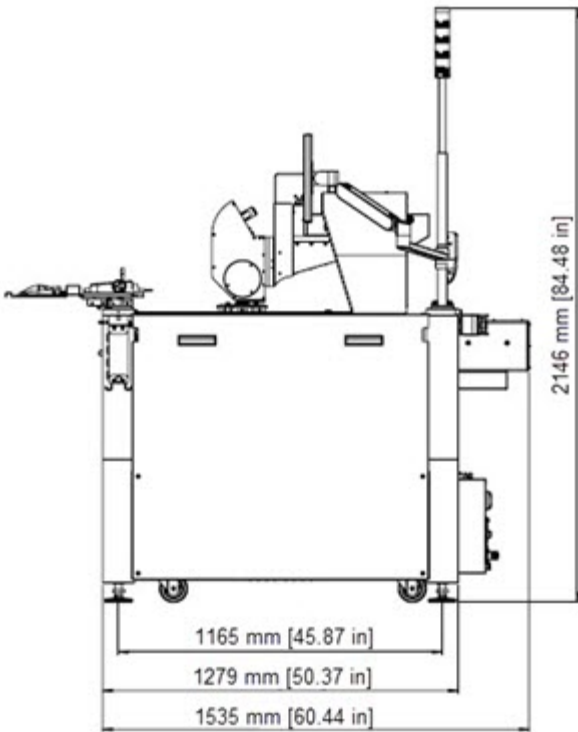

# CM300xi Probe System

## Fully-Automated Dual Probe Station with MHU300

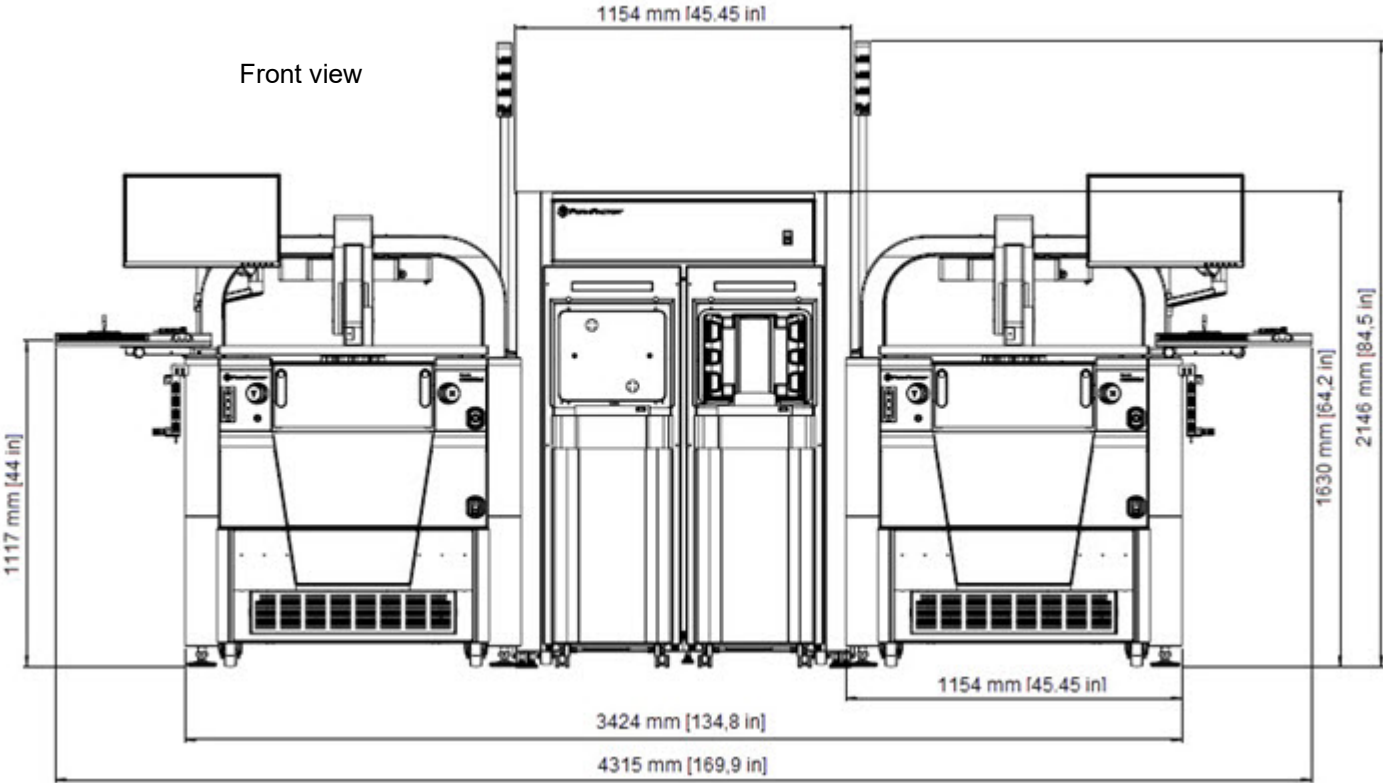

# CM300xi Probe System

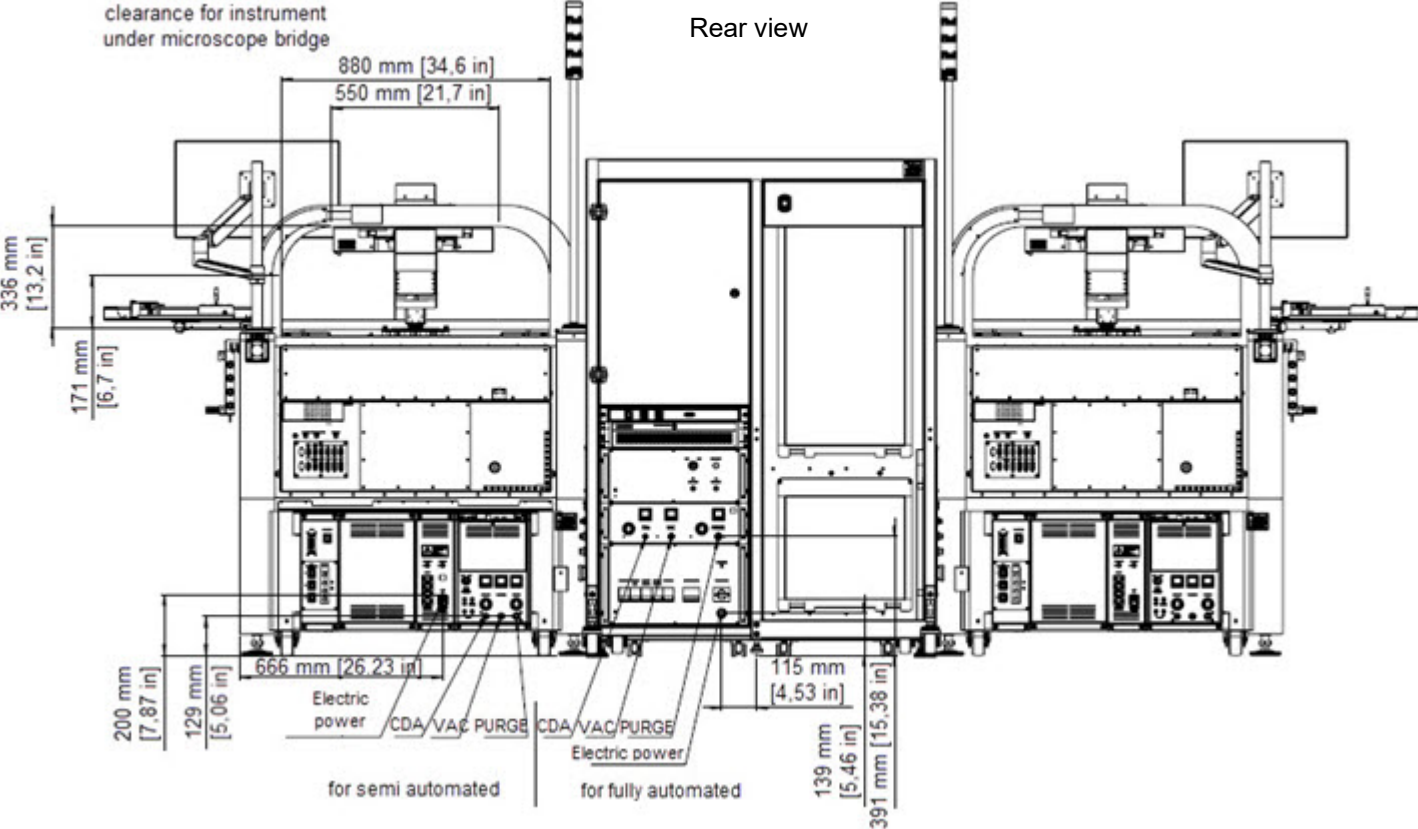



# CM300xi Probe System

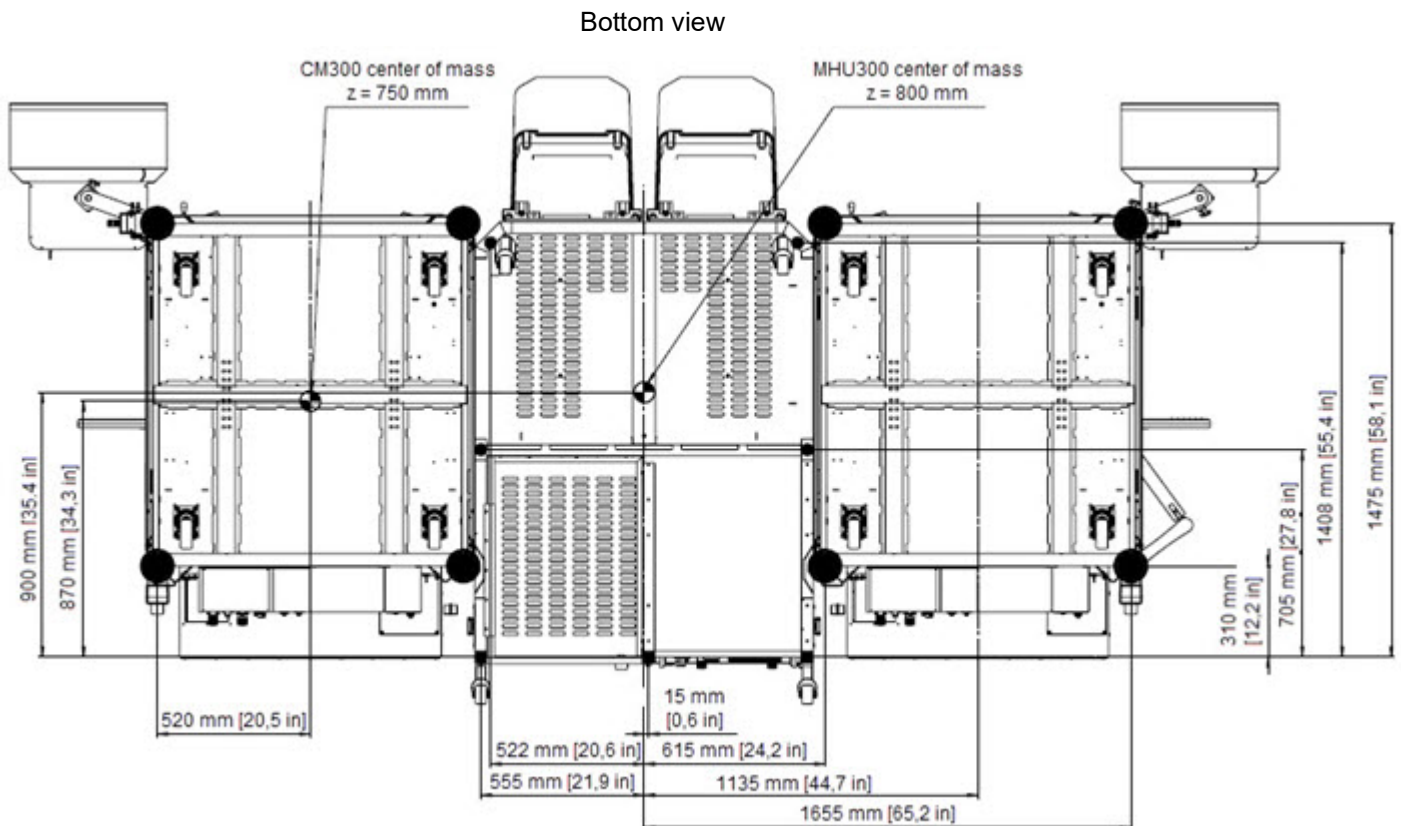
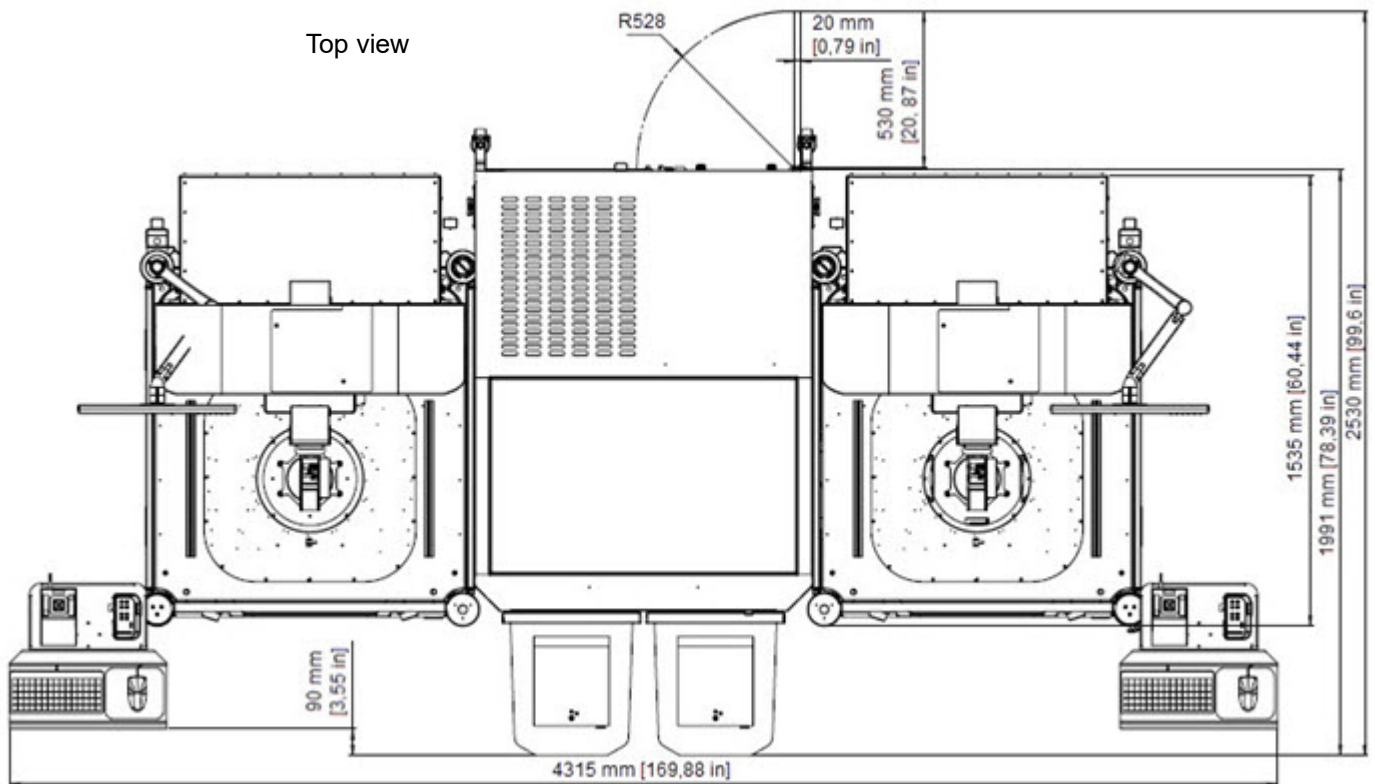

# CM300xi Probe System

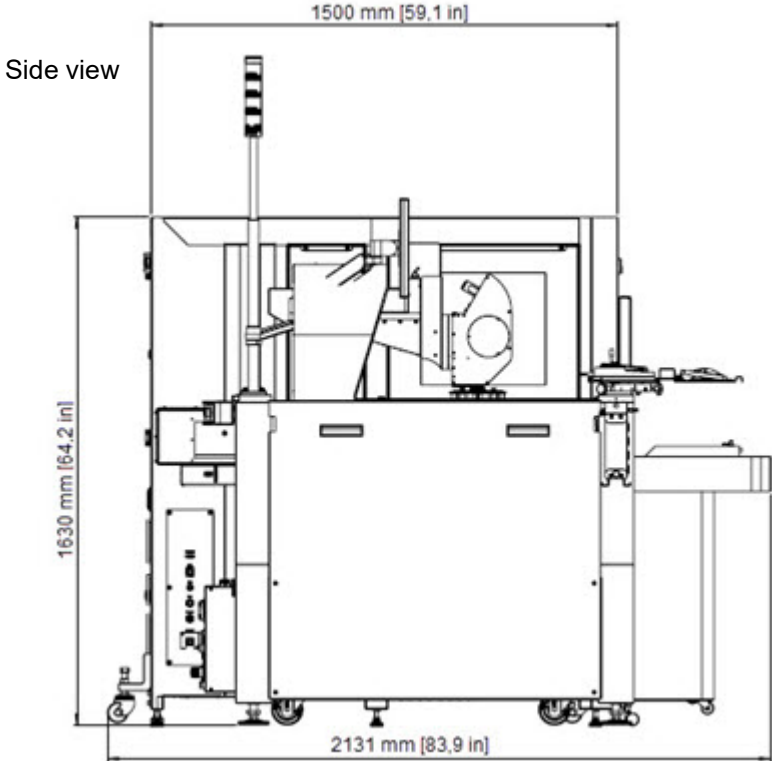

## Fully-Automated Probe Station with MHU301

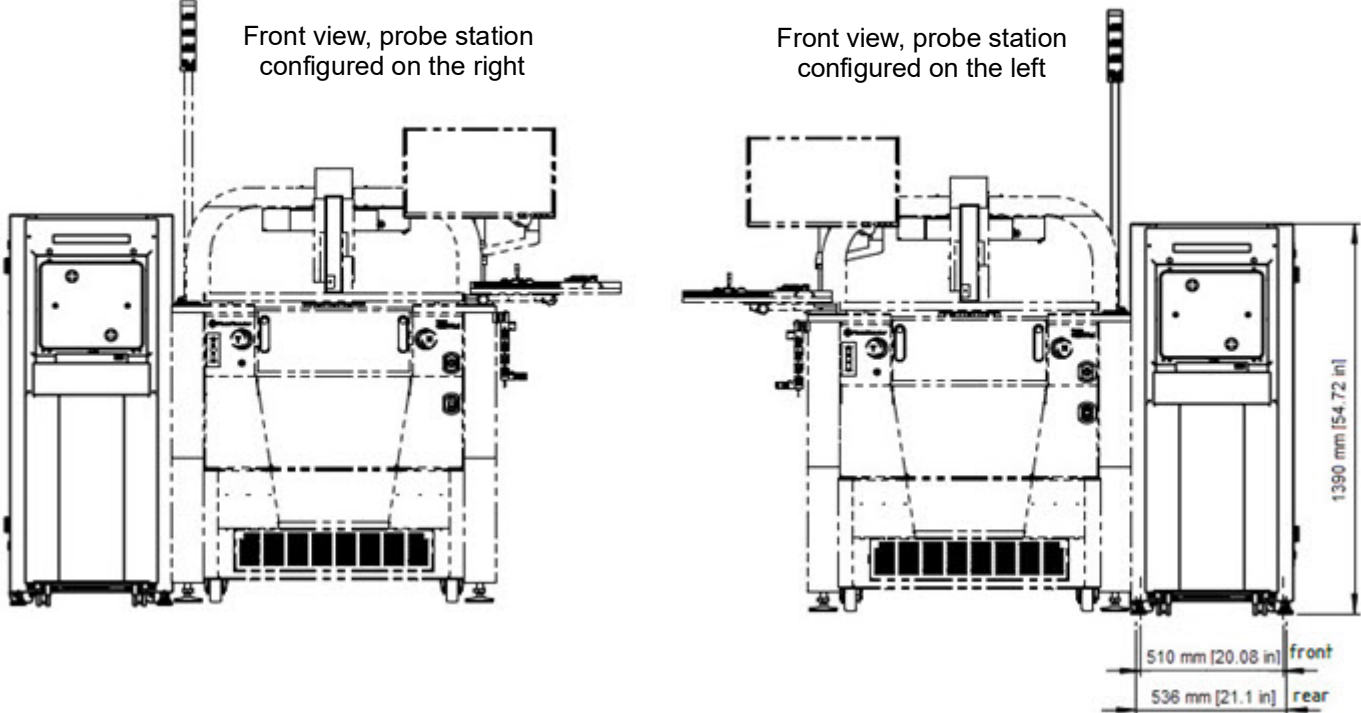

# CM300xi Probe System

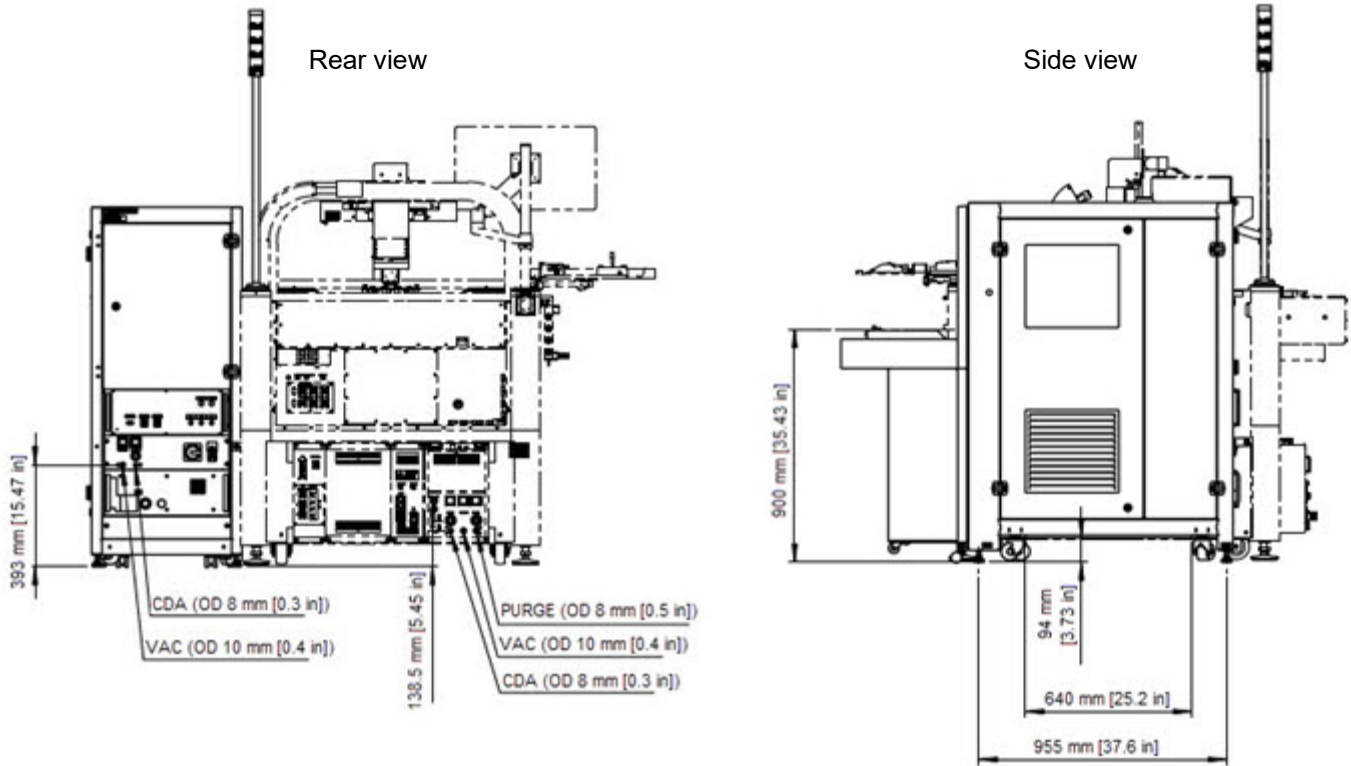

# CM300xi Probe System

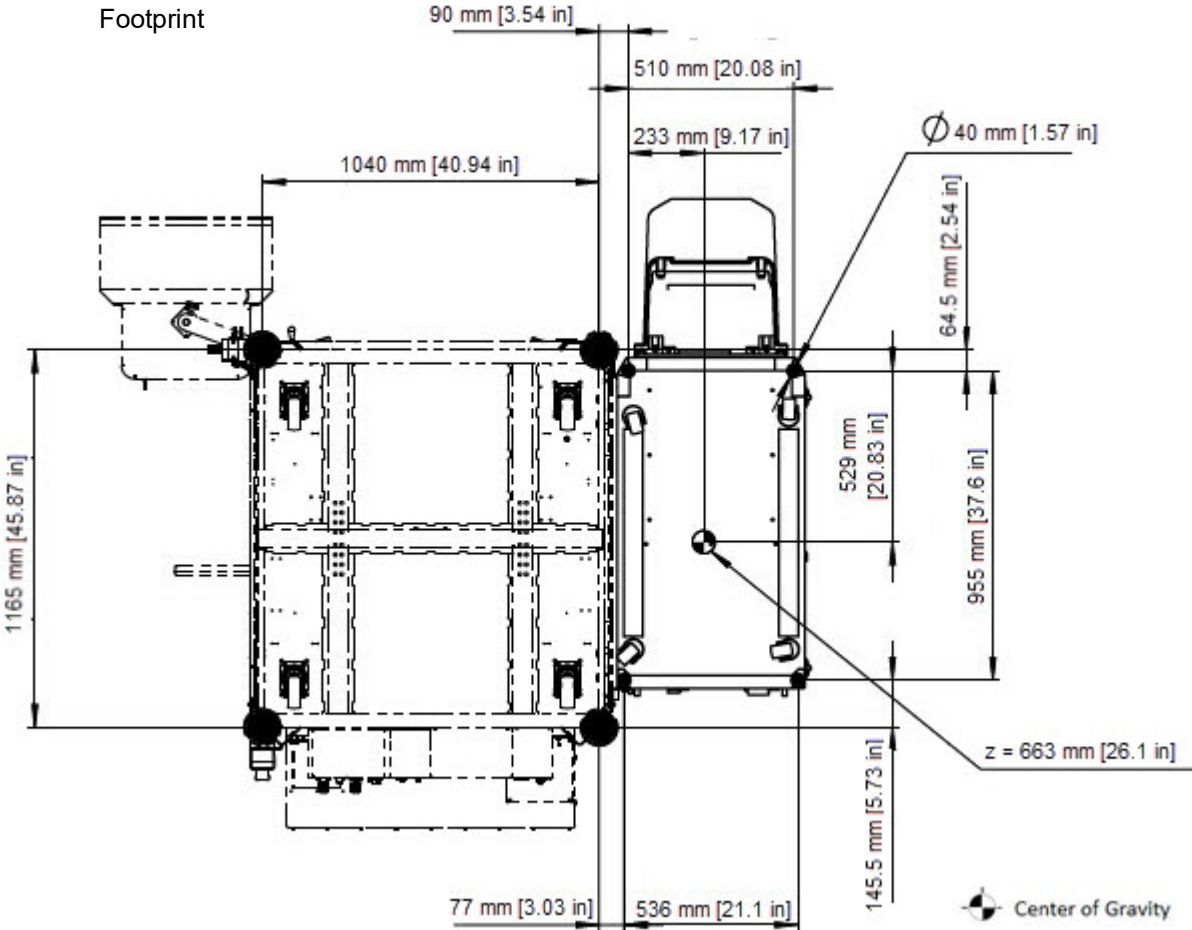

# CM300xi Probe System

Top view, configured on the right

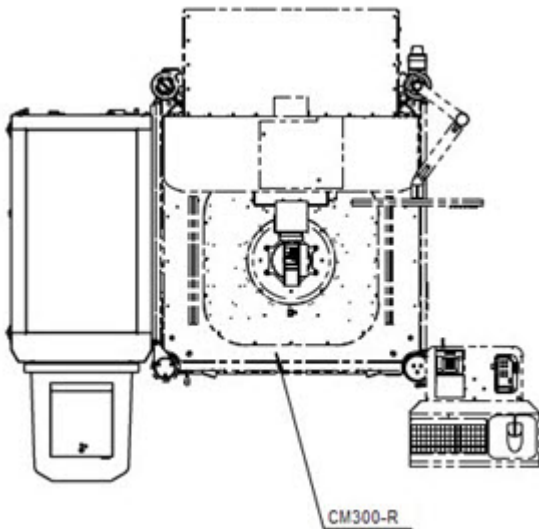

Top view, configured on the left

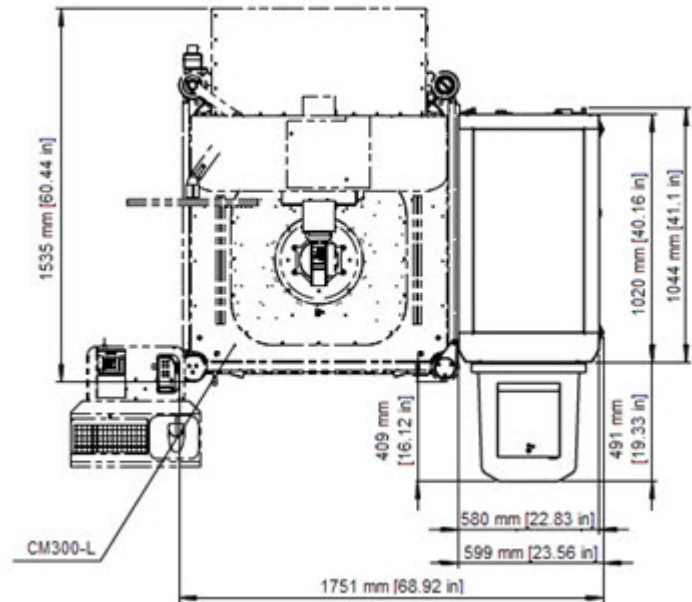

© Copyright 2018 - 2024 FormFactor, Inc. All rights reserved. No part of this document may be reproduced, transmitted or displayed in any form or by any means except as duly authorized by FormFactor, Inc. FormFactor and the FormFactor logo are trademarks of FormFactor, Inc. All other trademarks are the property of their respective owners.

## Important Notice

While the information contained herein is believed to be accurate as of the date hereof, no express or implied representations or warranties are made with respect to its accuracy or completeness. FormFactor, Inc., and its subsidiaries disclaim liability for any inaccuracies or omissions. All information is subject to change without notice.

Users are required to read and follow carefully all safety, compliance and use instructions. Users assume all loss and liability arising from the use of products in any manner not expressly authorized. The conditions and methods of use of products and information referred to herein are the entire responsibility of the user and, to the maximum extent permitted by applicable law, FormFactor, Inc., and its subsidiaries shall not be liable for any damages, losses, costs or expenses arising out of, or related to, the use thereof.

No license, express or implied, by estoppel or otherwise, under any intellectual property right is granted in connection herewith. Users shall take all actions required to avoid intellectual property infringement.

## Corporate Headquarters

7005 Southfront Road  
Livermore, CA 94551  
Phone: 925-290-4000  
[www.formfactor.com](http://www.formfactor.com)

